



Quadro would like to thank you for choosing this vehicle.

This high-quality vehicle is fitted with a state-of-the-art engine designed using the latest technologies and has been assembled using components of the highest standards.

This handbook provides you with all the information, including suggestions, warnings and cautions, which are necessary for you to become familiar with the vehicle and to appreciate its features, capabilities and limitations, in order to ensure a safe ride.



Quadro 350D



Please read this owner's handbook before riding the vehicle.



2





Quadro 3500



TABLE OF CONTENTS





TABLE OF CONTENTS

Cap.01 Foreward	7
1.1 General	8
1.2 Main standards for documentation	9
1.3 Manufacturer and technical services	10
Cap.02 Warnings and safety	11
2.1 Warnings labels	12
2.2 Main safety rules	13
2.3 Safety rules for maintenance	19
2.4 Safety devices and protections	20
2.5 Residual risks	20
2.6 Liability and limitations of use	21
2.7 Unauthorised modification	21
Cap.03 Handling and trasportation	23
3.1 Preliminary operation	24
3.2 Handling	24
3.3 Trasportation	24
Cap.04 Vehicle description	25
4.1 Veichle identification plate	26
4.2 Intended use	26
4.3 Unforeseen and incorrect use	26
4.4 Technical specification	28
4.5 Position components	34
4.6 Controls	35
4.7 Instruments panel layout	35
4.8 Low oil pressure warning lighjt	36
4.9 Left handlbar switches	36



4.10 Right handlebar switches	37
4.11 Ignition keys	38
4.12 Steering lock	38
4.13 Ignition switch.....	38
4.14 Fuel tank.....	39
4.15 Parking brake lever	49
4.16 Helmet compartment	40
4.17 Front glove box	40
4.18 Rear luggage rack.....	41
4.19 Top case	41
4.20 Serial numbers	42
4.21 Centre stand	43
4.22 Exhaust system	43
4.23 Rear view mirrors.....	44
4.24 Automatic transmission	44
4.25 Hydraulic tilting system (HTS)	45
4.26 Shock absorber adjustment	46
Cap.05 Riding the vehicle	47
5.1 Preliminary checks	48
5.2 Tyres inflation pressures	49
5.3 Refuelling	49
5.4 Starting the engine.....	50
5.5 Stopping the engine	52
5.6 Running-in	52
5.7 Safe operation	54
Cap.06 Vehicle maintenance	55
6.1 General	56



6.2 Safety instructions for maintenance	57
6.3 Daily checks	58
6.4 Engine oil	58
6.5 Final drive oil	61
6.6 spark plug	62
6.7 Draining evaporated oil	63
6.8 Battery	64
6.9 Fuse box	66
6.10 Airbox	66
6.11 Tyres	68
6.12 Coolant	69
6.13 Brake fluid	70
6.14 Front and rear brake discs	72
6.15 Headlights	74
6.16 Tail/brake light and direction	74
6.17 Licence plate light	75
6.18 Scheduled maintenance	76
6.19 Extraordinary maintenance	78
6.20 Accessories and spare parts	78
6.21 Troubleshooting guide	79
6.22 Tyre puncture	80
6.23 Cleaning the vehicle	80
6.24 Recommended products	81
6.25 Tools kit	81
Cap.07 Vehicle inactivity	83
7.1 Vehicle inactivity	84
Cap.08 Smantling and disposal	87
8.1 Vehicle dismantling and disposal	88



Quadro 3500



CHAP.1 FOREWORD





FOREWARD



Please read this handbook before riding your vehicle

1.1 GENERAL

This handbook is an essential and permanent part of your vehicle.

All riders must read this owner's handbook and all other instructions which are supplied with your vehicle, before riding

Do not lend your vehicle to anyone who has not read and understood the instructions contained in this handbook.

This handbook contains simple and clear descriptions regarding the operations necessary to understand and ride your vehicle, as well as all recommendations that will allow you to operate your vehicle safely and to avoid injuries to yourself and your passengers. It also includes descriptions of the main maintenance operations and of the required regular inspections.

To ensure the proper operation and safe use of your vehicle you must strictly follow all instructions contained in this handbook.

This handbook and the declaration of conformity must always accompany your vehicle and should remain with it even if your vehicle is subsequently sold.

This owner's handbook is a permanent part of your vehicle and it must be kept in a safe place and remain accessible to anyone who may ride your vehicle.

In case of loss or deterioration of this owner's handbook, please ask your dealer to provide you with a replacement for your vehicle.



1.2 MAIN STANDARDS FOR DOCUMENTATION

UNI 10653:1197 "Technical documentation. Quality of technical documentation"

UNI 10893:2000 "Technical documentation. Instructions for use. Breakdown and outline of contents".

UNI 11083:2003 "Technical documentation. Guidelines for the preparation of user and training guides".

UNI/TS 1192:2006 "Technical documentation. Life cycle models and document allocation".

Draft standard U30.00.055.0 "Technical information. Methods for the evaluation of user guides drafted for technical goods".

CEI EN 62079:2002 "Instructions preparation - Structure, content and presentation".

ISO 7000:2004 "Graphical symbols for use on equipment - Index and synopsis".

UNI EN 12100-2:2005 "Safe use of machinery. Basic concepts, general design principles". Part 2: Technical principles

QUADRO



1.3 Manufacturer and technical services

Quadro
Vehicles S.A.



QUADRO



Quadro 350D



CHAP.2 WARNINGS AND SAFETY





WARNINGS AND SAFETY

2.1 WARNING LABELS

The labels below are important to thoroughly understand this handbook: they indicate those sections that you must pay utmost attention to. The symbols differ from one another in order to clearly identify the various subjects and their relevant field.



Please read this handbook before riding your vehicle



BURN HAZARD

Failure to comply with the instructions marked with this symbol may result in serious burn hazards.



DANGER MOVING PARTS

Failure to comply with the instructions marked with this symbol may result in danger of dragging, crushing and cutting.



ELECTRICAL SHOCK AND BURN HAZARD

Failure to comply with the instructions marked with this symbol may result in burn hazards and electrical shocks.



HEALTH & SAFETY

Failure to comply with the instructions marked with this symbol may lead to severe injuries.



WARNING

PRESERVING YOUR VEHICLE

Failure to comply with the instructions marked with this symbol may lead to severe damages to your vehicle's components and/or safety features, and in some instances, void your warranty.



ATTENTION



PRESERVING THE ENVIRONMENT

All instructions marked with this symbol indicate the correct actions to follow in order to preserve the environment



DANGER EXPLOSION

Failure to comply with the instructions marked with this symbol may result in extreme danger to people.



WARNINGS AND SAFETY



RESIDUAL RISKS

DANGER

Shows the presence of dangers that cause residual risks to which the user must pay attention in order to avoid injury or damage.



DANGER: FLAMMABLE LIQUIDS

Failure to comply with the instructions marked with this symbol may result in extreme danger to people.



DO NOT LUBRICATE MOVING PARTS

Failure to comply with the instructions marked with this symbol may result in extreme danger to people.



DO NOT REMOVE PROTECTIONS

Failure to comply with the instructions marked with this symbol may result in extreme danger to people.



WEAR PROTECTIVE CLOTHES

Failure to comply with the instructions marked with this symbol may result in extreme danger to people.



WEAR PROTECTIVE GLOVES

Failure to comply with the instructions marked with this symbol may result in extreme danger to people.



WEAR SAFETY SHOES

Failure to comply with the instructions marked with this symbol may result in extreme danger to people.



FUEL

QUADRO



WARNINGS AND SAFETY

2.2 MAINSAFETY RULES



All riders must read this owner's handbook before riding your vehicle with particular attention to be given to the chapter related to warnings and safety.

All riders must follow the instructions below, in addition to general precautions to be observed while riding the vehicle. Especially:

- Read this handbook carefully to learn about the operation, safety equipment and all necessary precautions. This will allow you to ride the vehicle safely.
- This vehicle has been designed and built to be ridden outdoors by experienced adult riders.
- Petrol (fuel) is highly flammable and can be explosive under certain conditions. You must always refuel in a well ventilated area and with the ignition switch turned to the OFF position.
- Do not smoke while refuelling and/or in the vicinity of fuel storage areas. Make sure the refuelling area is free from any source of flame or sparks.
- Do not overfill the fuel tank. After refuelling, make sure the cap has been securely and appropriately locked.
- Make sure there are no fuel leaks during refuelling. Fuel vapours or possible leaks may ignite. Ensure that the fuelling area is completely dry before starting the engine.
- Do not start the engine indoors; exhaust gases are highly toxic and can cause loss of consciousness or even death of the person exposed.
- In the event that fuel comes into contact with your eyes, you must seek immediate medical attention.



WARNINGS AND SAFETY

- The muffler becomes hot during operation and it will remain hot for period of time after turning off the engine; be careful not to touch it when hot.
- In parking spaces, you must pay particular attention that the muffler does not come into contact with flammable materials as this may cause fires and/or burns.
- Do not push the vehicle beyond its design range of performance limitations. Only ride the vehicle in accordance with the terms of use described in this handbook.
- Never ride the vehicle with any of its parts missing.
- Ride with both hands safely on the handlebars.
- Replace any worn and/or damaged components and ensure that the safety devices work correctly before riding. If necessary, have the vehicle inspected by qualified service personnel.
- Do not start the vehicle at full throttle as this may lead to loss of control with the risk of damage and injury to people.
- Brake fluid is highly corrosive; avoid contact with the skin and eyes. In case of accidental contact, rinse thoroughly with water.
- Do not open the expansion tank filler cap when the engine is still hot; burn hazard.
- Please bear in mind that when riding on long stretches of wet roads without operating the brakes their effect will decrease. It is therefore highly recommended that you operate them periodically to ensure an efficient braking action.



WARNINGS AND SAFETY

Before riding always consider your psychophysical conditions, tiredness state and somnolence.

Never ride your vehicle when fatigued or under the influence of alcohol or other drugs.

Riding when under the influence of alcohol or other drugs is illegal; it reduces the rider's ability to maintain control of the vehicle and may lead to loss of control and an accident.



In accordance with the local traffic laws, all vehicles can only circulate with their low beam lights on at all times, even during the day.

Please refer to the traffic regulations in force in your country in order to determine all necessary requirements for riding the vehicle, i.e. minimum age, driving license, documents, etc.

Please observe all national traffic rules, avoid sudden manoeuvres that could be dangerous for yourself and others, and always consider the road surface conditions.

We recommend first becoming familiar with your vehicle and all its functions in private or low-traffic areas.

Do not ride in the slipstream of vehicles ahead of you in order to increase your speed; do not stand up or stretch while riding. Do not let yourself distract by people, things, or actions (drinking, eating, smoking, etc.) while driving. The rider must have arms, hands and legs free; must be sitting in a correct position and hold the handlebars securely with both hands or, if necessary, with one hand when signalling as per your local traffic regulations.



WARNINGS AND SAFETY



Do not hit obstacles as this may lead to the loss of control of your vehicle and/or cause damages to your vehicle and injure people.

Do not ride your vehicle after it has been damaged in a way that may affect its operation and safety standards.

Do not change the position and inclination of the license plate, the direction indicators, the light units and the horn.

Any modification or removal of original parts may jeopardize your vehicle's performance, alter its safety features and/or make it illegal for road use.

Observe your local traffic rules and regulations concerning vehicle equipment. It is absolutely necessary to avoid any modifications altering the original features of the vehicle.

Unauthorised street racing on public property is forbidden and will be sanctioned by the competent authorities.

Riding this vehicle in any kind of competitive race, modifying its functionality, and the use of non genuine spare parts will result in its warranty to be void immediately.



Periodically inspect the levels of oils, fuel, and coolant. Use exclusively products of the recommended type, according to the instructions under the section «Scheduled Maintenance / Recommended Products».

Please report any malfunction to your local service centre. Should the vehicle be involved in an accident or fall, check the functionality of all levers, cables, hoses and main parts, and contact a service centre that will inspect the damages and the safety standards of the vehicle.



WARNINGS AND SAFETY

Protective equipment



WARNING

All riders must be wearing a helmet at all times. You must ensure that your helmet meets requirements set by your local authorities. It must be in good condition, and it must fit your head comfortably and securely. Always check that it is well fastened before riding.

Accessories



ATTENTION

Use only accessories that have been approved for your vehicle. The rider is responsible for the choice and use of the accessories fitted to the vehicle.

Quadro recommends using original accessories.

Loading



WARNING



ATTENTION

Respect the prescriptions of the rules in force: do not exceed the allowed load limit, and do not transport more persons than foreseen by the approval certificate.

According to the current regulations it is forbidden to carry children under 5 years of age.

Transport objects inside the special compartments only as required by law: transported objects shall be well fastened, they shall not protrude laterally or longitudinally respectively from the vehicle's axis or profile by over 50 cm as this may hinder or limit the rider's visibility. You are allowed to transport animals, provided that they are kept in a proper cage or case, observing the limits described above.



WARNINGS AND SAFETY

2.3 SAFETY RULES FOR MAINTENANCE

- All maintenance procedures must be carried out when the vehicle is not running and is securely placed on its centre-stand.
- During each maintenance phase, all users must be wearing the required safety equipment at all times (gloves, glasses, work clothes).
- Use only suitable and good-quality tools for your maintenance operations.
- Always keep the area used for maintenance clean and dry, paying particular attention in ensuring that any oil stains are removed.
- Never insert limbs or fingers inside any of the uncovered openings of the vehicle.
- Do not use fuel or flammable solvents as detergents, but always use non flammable and non-toxic solvents.
- Minimize the use of compressed air (2 bar max.) and wear safety goggles with side protections.
- Never use open flames for illumination when carrying out maintenance checks.
- After each maintenance procedure or adjustment, make sure that no tools or foreign objects have been left between the moving parts of the vehicle in order to avoid damage to the vehicle and/or injury to people.

WARNINGS AND SAFETY

Safety devices



Fig.01_02

Protections



Fig.02_02

2.4 SAFETY DEVICES AND PROTECTIONS

The vehicle is fitted with the following safety devices:

1. Parking brake lever
2. Steering lock
3. Hydraulic Tilting System

The vehicle is fitted with the following protections:



A. Hydraulic tilting system «2» cylinder cover.



B. Muffler heat shield «3».



DANGER



Therefore, it is strictly forbidden to modify or remove any protection from the vehicle or its warning labels and plates.

2.5 RESIDUAL RISKS

The list of residual risks resulting from protections is shown in the illustration 02_02 and marked with hazard symbols.

WARNINGS AND SAFETY

2.6 LIABILITY AND LIMITATIONS OF USE



Failure to follow all operating instructions and safety requirements contained within this document relieves the manufacturer from any liability. By riding this vehicle, the rider accepts all risks associated with its use.

If the vehicle maintenance was performed in a manner that was not conforming with the instructions provided, using non original spare parts or in any manner that could harm its integrity or change its properties, the manufacturer shall be deemed exonerated from any responsibility regarding the safety of persons and operating faults of the vehicle.

2.7 UNAUTHORISED MODIFICATIONS



WARNING

Do not modify the vehicle in any way. Any attempt in this regard, in addition to voiding the warranty, may affect its operation causing malfunction or accidents.

Extraordinary maintenance work on the vehicle must be performed only by specialised and authorised personnel.

If you hear unusual noises or notice anything strange, stop the vehicle immediately. Carry out an inspection and then, if necessary, contact Customer Service.



WARNING

It is absolutely forbidden to modify the purchased vehicle to increase its performance.

The manufacturer **Quadro** assumes no responsibility for accidents or damages caused by modifications or accessories fitted unless expressly authorised.



WARNINGS AND SAFETY





Quadro 350D



**CAP.3 HANDLING AND
TRANSPORTATION**





HANDLING AND TRANSPORTATION

3.1 PRELIMINARY OPERATION

The vehicle is shipped in perfect operating condition, ; it comes packed in bubble wrap, anchored to a wooden pallet and then inserted in a cardboard box.

Upon receipt, unpack it and check the integrity of the vehicle; in case of damage, inform the seller and the carrier.



Packing material (cardboard, wooden pallet, bubble wrap, plastic bags, etc.) should be kept out of the reach of children as these are potentially dangerous.

3.2 HANDLING

The vehicle weighs approx. 200 Kg, therefore it should only be handled using suitable lifting devices. We recommend using a forklift or a sling.

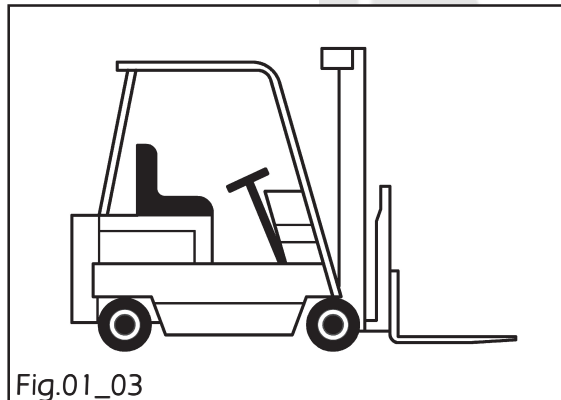

Fig.01_03

3.3 TRANSPORTATION

To transport the vehicle, please observe the following procedure:

- Turn the engine off.
- Use purpose-made tie-downs to secure the vehicle; you must not use common straps as these may come undone.
- Use tie-downs to secure the vehicle to the transport in order to prevent it from slipping and/or falling.
- Reduce your speed when transporting the vehicle, especially around corners.



Quadro 350D



CHAP.4 VEHICLE DESCRIPTION





VEHICLE DESCRIPTION

Quadro tecnologie S.r.l.
e 24 *2002/24*XXXX
ZLY3D3130XTXXXXXX
XX dB (A) at XXXX rev/min

4.1 VEHICLE IDENTIFICATION PLATE

Your vehicle identification plate summarises the following information:

- Manufacturer's name and address
- Type
- Serial number
- Year of manufacture
- Sound level
- Rev/min

4.2 INTENDED USE

This vehicle is intended to be ridden only outdoors.

This vehicle has been certified for road use and for the transportation of a rider and a passenger.

Using this vehicle in any way other than that intended is strictly forbidden, unforeseen by the manufacturer and, therefore, extremely dangerous.

4.3 UNFORESEEN AND INCORRECT USE

This vehicle has designed and built for the use specified; any use other than the one specified by the Manufacturer is strictly forbidden, and may constitute a hazard to users.



VEHICLE DESCRIPTION



WARNING

YOU MUST NOT, UNDER ANY CIRCUMSTANCE:

- Start the engine indoors. Exhaust gases from the engine contain carbon monoxide and other toxic volatile substances, which, if inhaled, may lead to death.
- Ride the vehicle indoors or in open areas lacking good ventilation/air circulation.
- Touch the engine or muffler when hot.
- Ride your vehicle under the influence of alcohol or drugs.
- Ride your vehicle if you are under 18 years of age or do not fulfil your local requirements.
- Use non original spare parts.
- Have unauthorised personnel performing maintenance or procedures not expressly described within this handbook.
- Carry out any maintenance operation while the engine is running.
- Perform operations or procedures which are described in the owner's handbook.
- Pull away while your vehicle is still on its centre stand and, in any case, ensure that rear wheel does spin as it comes into contact with the ground in order to avoid the loss of control of the vehicle.
- Adjust your rear-view mirrors while riding as this may lead to the loss of control of the vehicle.

 **VEHICLE DESCRIPTION**

4.4 TECHNICAL SPECIFICATIONS

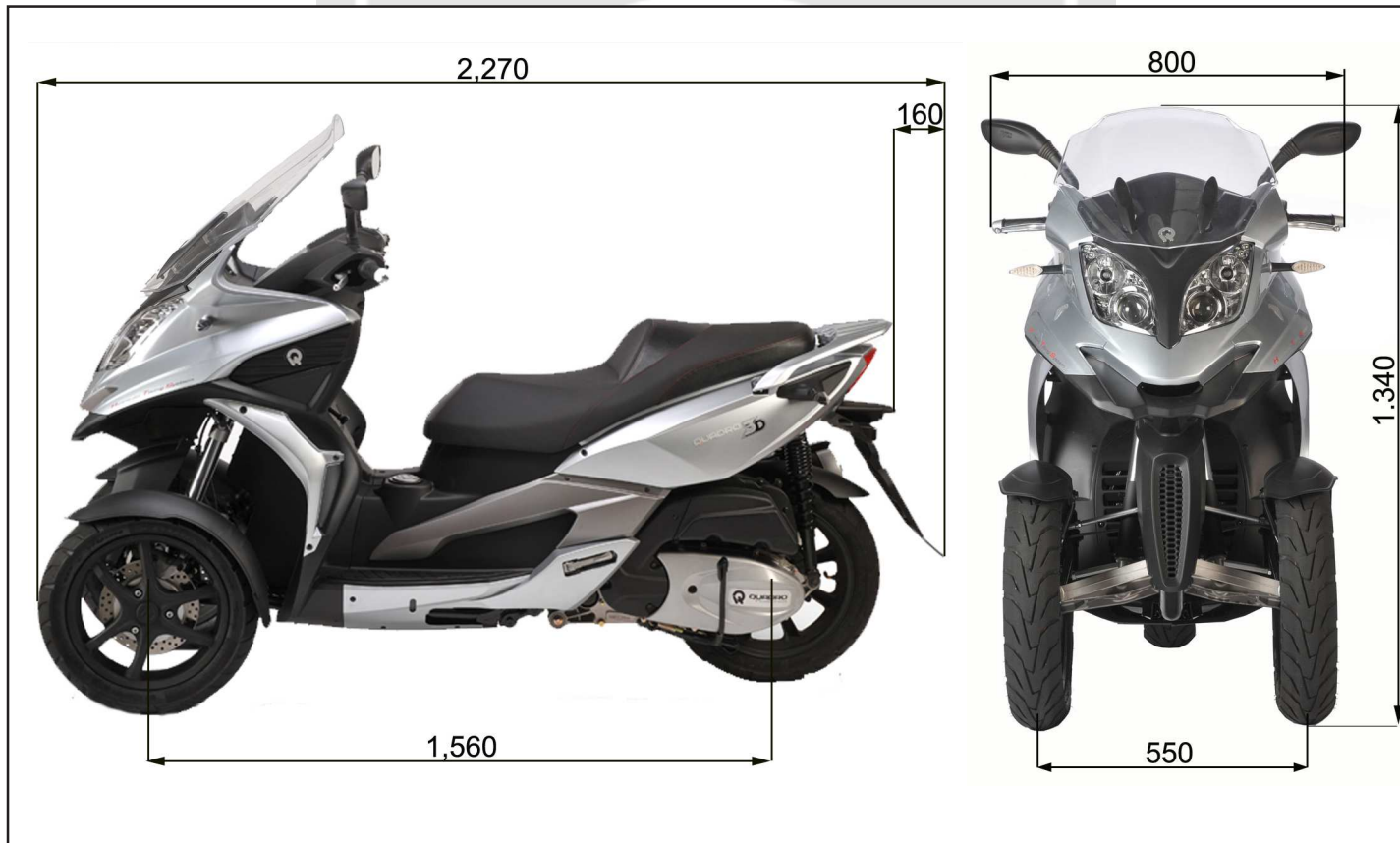

VEHICLE DESCRIPTION

VEHICLE SPECIFICATION	UNIT OF MEASURE	
Length	mm	2.270
Wheel base	mm	1.560
Track	mm	550
Width (at handlebar)	mm	800
height (at headlight fairing)	mm	1.340
Seat height (standard)	mm	830
Seat height (low)	mm	780
Unladen mass	kg	210
Mass of the vehicle in running order	Kg	220
Technically permissible mass	Kg	480
Fuel tank capacity	l	13,0
Fuel Reserve capacity	l	3,0
Frame	-	Steel trellis reinforced with welded plates
Seats	-	2
Front suspension	-	HTS forks (Adjustable hydraulic tilting system)
Rear suspension	-	Single spring damper with preload adjustment
Front brake (disc brake)	mm	240
Rear brake (disc brake)	mm	256
Front wheel rim	in	14 x 2,75
Rear wheel rim	in	15 x 3,5
Front tyre	-	Tubeless 110/80-14" 53P
Rear tyre	-	Tubeless 140/70-15" 69P
Front tyre pressure	bar	1,5
Rear tyre pressure	bar	2,3 single driver (2,5 with passengers)



VEHICLE DESCRIPTION

ENGINE SPECIFICATION	UNIT OF MEASURE	
Identification code	-	T62N
Type	-	Single-cylinder four-stroke engine with 2 valves
Displacement	cm ³	313
Bore x stroke	mm	78 x 65,6
Compression ratio	-	10,6 : 1
Max. power	kW / rpm	15,4 a 7000
Max. torque	Nm / rpm	23,7 a 6000
Starting system	-	Electric
Engine idling speed	rpm	1600 ± 100
Engine oil	l	SAE 10W-60 API SJ (1,7 l)
Transmission	-	Centrifugal dry clutch, V-Belt, CVT (Continuous Variable Transmission)
Final drive	-	Wet gears
Transmission oil	l	SAE 80W-90 (180 cm ³)
Lubrication	-	Pressure lubrication (wet sump)
Cooling system	-	Liquid, fan-assisted
Fuel system	-	Electronic fuel injection
Fuel	-	95 RON unleaded
Ignition system	-	Digital inductive
Spark plug	-	NGK DPR7EA-9
Exhaust system	-	Catalytic converter
Exhaust gas emission standards	-	Euro 3



VEHICLE DESCRIPTION

ELECTRICAL EQUIPMENT	
Battery	12V 12Ah
Headlight - Daytime Running Light	12V LED
Headlight - High/Low Beam	12V/35-35W
Tail/Brake Light	12V LED
Direction Indicator Lights	12V LED
Instrument Panel Backlight	12V 3W
Horn	12V 1,5A
Fuse 30A	Protected circuits
Fuse 15A	Main
Fuse 10A	Light
Fuse 10A	EFI
Fuse 5A	Ignition
Fuse 15A 10° 5A	Spare fuse

QUADRO

VEHICLE DESCRIPTION

SCHEMA ELETTRICO GENERALE

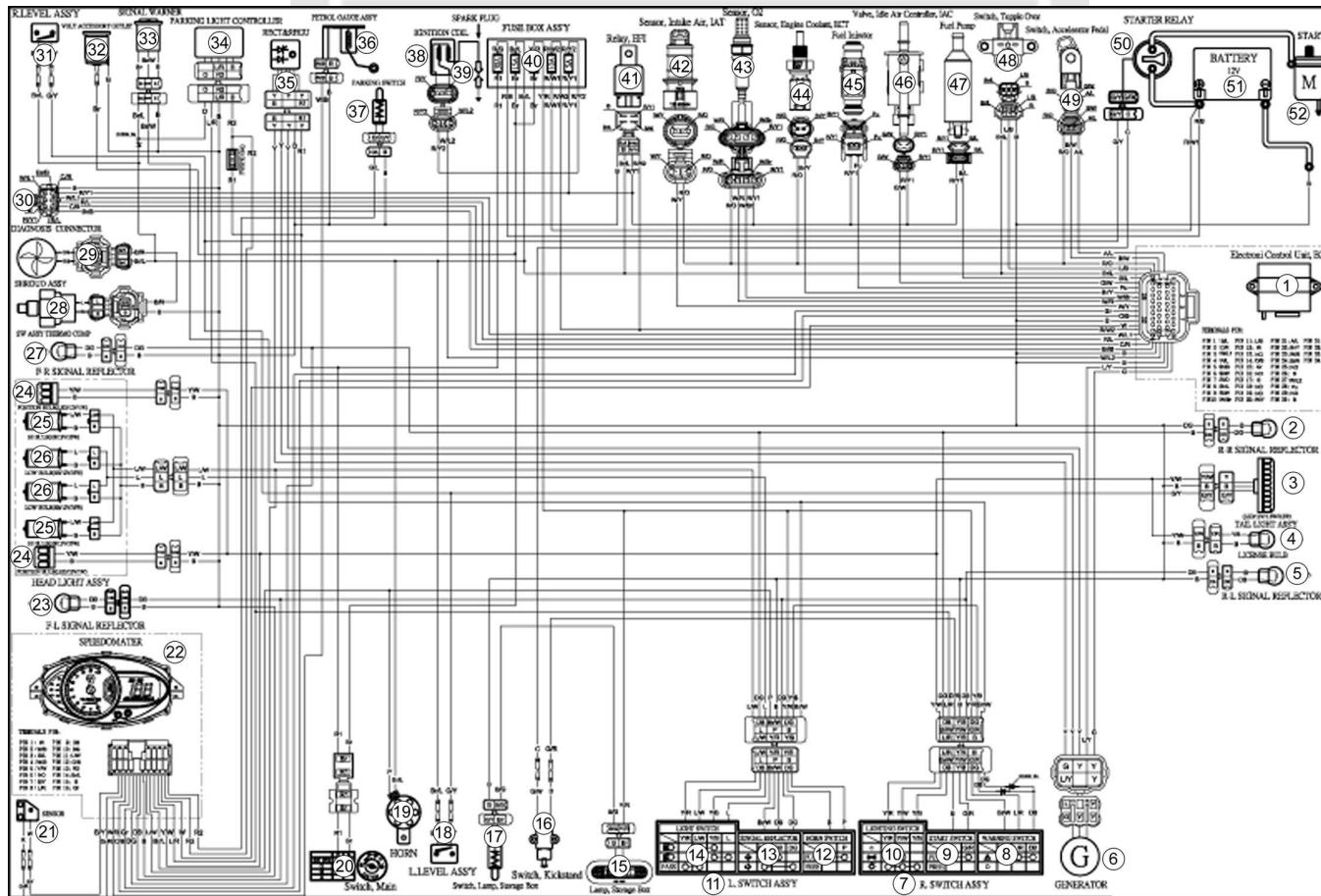



VEHICLE DESCRIPTION

Wiring diagram Key

1. Electronic control
2. Rh rear signal reflector
3. Tail light assy
4. Licence bulb
5. Lh rear signal reflector
6. Generator
7. Rh switch assy
8. Warning switch
9. Start switch
10. Lighting switch
11. Lh switch assy
12. Horn switch
13. Signal reflector
14. Light switch
15. Lamp storage box
16. Switch kitchstand
17. Switch lamp storage box
18. Lh level assy
19. Horn
20. Switch main
21. Sensor
22. Speedometer
23. Lh front signal reflector
24. Front position light bulb
25. Head light assy
26. Low light assy
27. Rh front signal reflector
28. SW assy thermo comp
29. Shroud assy
30. Diagnosis connector
31. Rh level assy

32. Volt accessory outlet
33. Signal warner
34. Parkling light controller
35. Rect&Regu
36. Petrol gauge assy
37. Parking switch
38. Ignition coil
39. Spark plug
40. Fuse box assy
41. Relay EFI
42. Sensor intake air
43. Sensor
44. Sensor engine coolant
45. Fuel iniecton
46. Valve idle air control
47. Fuel pump
48. Switch topple over
49. Switch accelerator pedal
50. Starter relay
51. Battery
52. Starter

Wires colour key

- | | |
|---|-------|
| G | Green |
| B | Black |
| W | withe |
| Y | Yelow |
| L | Blue |
| C | Cyan |
| P | Rosa |

- | | |
|------|--------------|
| R | Red |
| O | Orange |
| Gr | Gray |
| Br | Brown |
| L/B | Blue |
| B/Y | Yellow/black |
| L/G | Blue/green |
| G/L | Green/blue |
| W/G | Withe/green |
| B/L | Black/blue |
| O/B | Orange/Black |
| R/B | Red/Black |
| Y/W | Yellow/withe |
| L/R | Blue/red |
| Y/B | Yellow/black |
| W/Y | Withe/yellow |
| B/G | Black/grenn |
| G/Y | Green/yellow |
| B/Y | Black/yellow |
| C/R | Cyan/red |
| L/Y | Blue/yellow |
| R/L | Red/blue |
| R/O | Red/orange |
| Y/eR | Yellow/red |
| L/W | Blue/withe |
| G/W | Green/withe |
| W/Br | Withe/Brown |
| Br/B | Brown/black |
| Br/Y | Brown/Red |
| Gr/R | Gray/red |
| W/B | Withe/black |
| G/W | Green/withe |



VEHICLE DESCRIPTION

Right-hand View



Fig.01_04

Left-hand View



Fig.02_04

4.5 POSITION COMPONENTS

Right-hand View

1. Right-hand rear view mirror
2. Windscreen
3. Headlight assy
4. Right-hand passenger footrest
5. Engine oil dipstick
6. Exhaust
7. Taillight assy
8. Spark plug
9. Front glove box
10. Ignition switch
11. Right handlebar switches

Left-hand View

12. Left handlebar switches
13. Tank filler cap
14. Seat
15. Fuse box
16. Rear luggage rack
17. Airbox
18. Centre-stand
19. Passenger footrest (lhs)
20. Expansion tank
21. Battery
22. Horn
23. Instrument panel
24. Rear view mirror (lhs)



VEHICLE DESCRIPTION

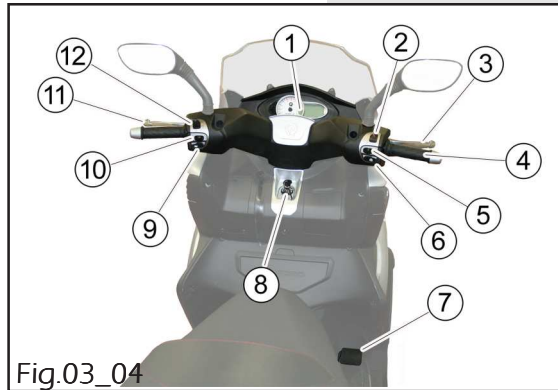

Fig.03_04

4.6 CONTROLS

1. Instrument panel
2. Hazard flashers
3. Front brake lever
4. Throttle grip
5. Headlight switch
6. Starter button
7. Combined braking pedal (front/rear)
8. Ignition switch
9. Horn button
10. Direction indicator switch
11. Combined braking lever (front/rear)



Fig.04_04

4.7 INSTRUMENT PANEL LAYOUT

- | | |
|---|---|
| 1. Tachometer | 10. Engine management malfunction indicator light |
| 2. Fuel level gauge/Cooling liquid temperature gauge | 11. High beam indicator light |
| 3. Speedometer | 12. Parking brake lever light |
| 4. Unit of measure (km/h / mph) | 13. Low fuel level indicator light |
| 5. Odometer/Trip meters | 14. High coolant temperature warning light |
| 6. 'Adjust' button | 15. Hazard flashers light |
| 7. 'Select' button – toggle through fuel and coolant liquid temperature gauge | |
| 8. Direction indicator light | |
| 9. Low oil pressure warning light | |



VEHICLE DESCRIPTION

4.8 LOW OIL PRESSURE WARNING LIGHT



This vehicle is fitted with a low oil pressure warning light that will illuminate when the ignition is switched «ON» . If the light comes on with the engine running, check the oil level and top up if necessary. If the warning light stays on after topping up, please contact an authorised service centre.

4.9 LEFT HANDLEBAR SWITCHES



Horn button «9»

When the horn button is pushed, with the ignition switch turned to the «ON»  position, the horn will sound .

Direction indicators switch «10»

With the key-operated ignition switch in «ON»  position, move the switch to the right «D» to activate the right-hand turn indicators  and on the left «S» to activate the left-hand turn indicators . After that, the lever automatically goes back in central position. Push the button «C» to deactivate the turn indicators.

Headlight Di Switch «12»

With the ignition switch turned to the «ON»  and light switch position, (low beam) (fig.06_04) can be selected with the headlight dip switch «12» . To select high beam, push the switch forward to position «M». To select low beam, push the switch rearwards to position «P» .

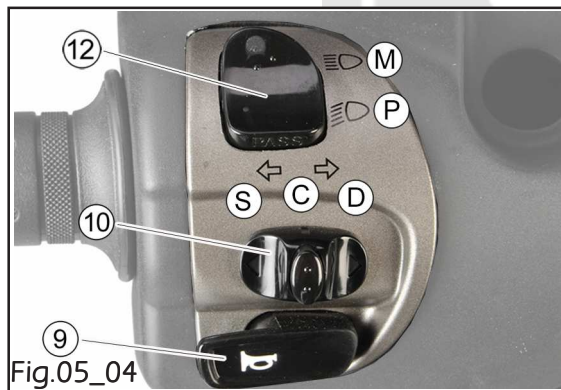

VEHICLE DESCRIPTION

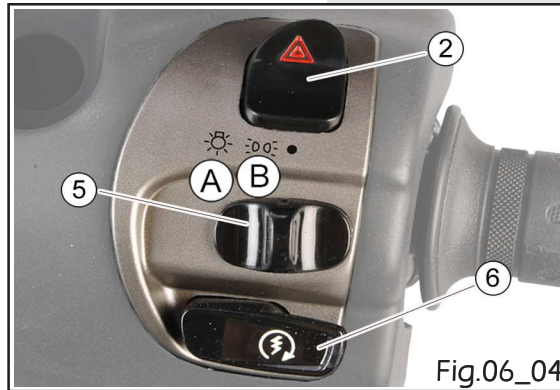



4.10 RIGHT HANDLEBAR SWITCHES



Hazard Flashers Switch «2»

To activate your vehicle's hazard flashers, push the switch «2» forward.

Headlight Switch «5»

With the key-operated ignition switch in «ON»  position and by placing the switch in «B» position, the parking lights  are activated. The low beams  are activated by placing the switch «A» position. As per rules of the road make sure to move even in the daytime with the lights switched on position.

Starter button «6»

The starter button «6»  operates the electric starter. For the starter to operate the ignition switch must be turned to the «ON»  position and the front brake lever must be pulled to the handlebar.

4.11 IGNITION KEYS

Your vehicle is delivered from the factory with two identical keys. In addition to operating the steering lock/ignition switch, the ignition key is required to operate the seat lock and fuel tank cap.



ATTENTION

IT IS HIGHLY RECOMMENDED THAT THE TWO KEYS ARE STORED SEPERATELY.

VEHICLE DESCRIPTION

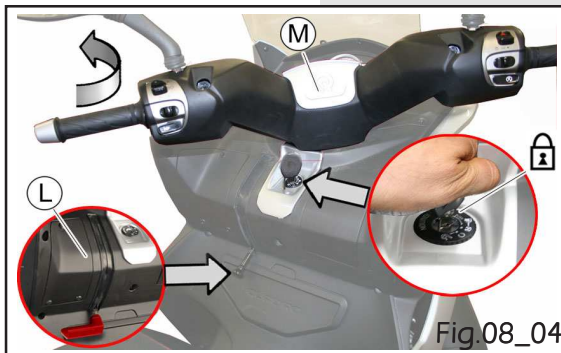

4.12 STEERING LOCK



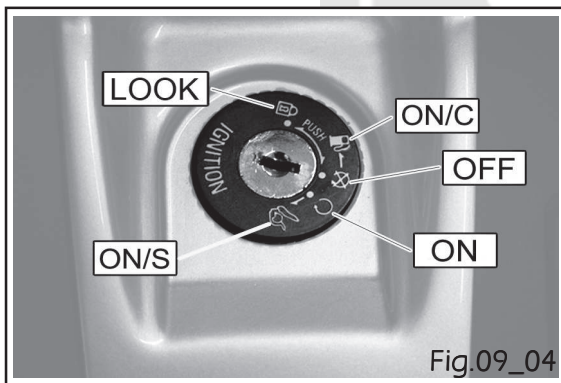

To activate the steering lock, proceed as follows:

- With the handlebar straight, push the parking brake lever «L» downwards.
- Turn the handlebar «M» fully to the left.
- Push and rotate the ignition key to the «LOCK»  position and remove it.
- The lever remains locked until the steering lock has been disengaged and the handlebar has been brought to a straight position.



4.13 IGNITION SWITCH

The ignition switch is located at the centre of the inner leg shield and is a 5 position key-operated switch. By rotating the key, it is possible to turn the switch to any of the following positions:

- «OFF»: the engine cannot be started. 
- «ON»: the engine can be started. 
- «LOCK»: the steering is locked and the engine may not be started. 
- «ON/S»: seat opening. 
- «ON/C»: fuel cap flap opening. 

VEHICLE DESCRIPTION

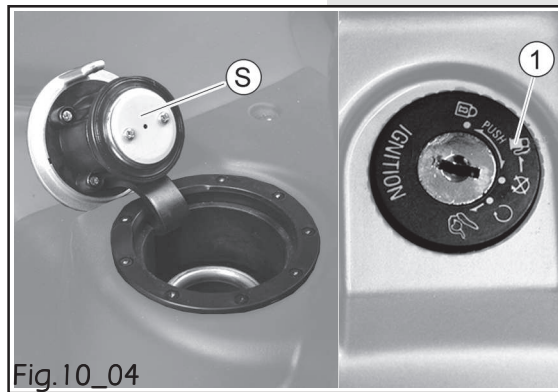

4.14 FUEL TANK



When refuelling, turn the ignition switch to the OFF position. Petrol (fuel) is highly flammable; you must keep any source of flame or sparks away from the area as these may lead to a fire hazard.

To gain access to the fuel tank, proceed as follows:

Rotate the ignition switch counter-clockwise to position «1» 
The tank cap flap «S» lifts automatically



ONLY USE UNLEADED FUEL WITH A MINIMUM OCTANE RATING OF 95 RON.



After refuelling always check that the fuel filler cap is correctly closed and locked

Fuel Tank Capacity: approx. 13 l Fuel Reserve Capacity: approx. 3 l

4.15 PARKING BRAKE LEVER

The parking brake lever «L» is located on the upper part of the inner leg shield.

When the parking brake lever «L» is in position «3» the wheels spin freely and the vehicle is in riding mode.

When the parking brake lever «L» is in position «2» the rear wheel and the HTS system are locked in parking mode.

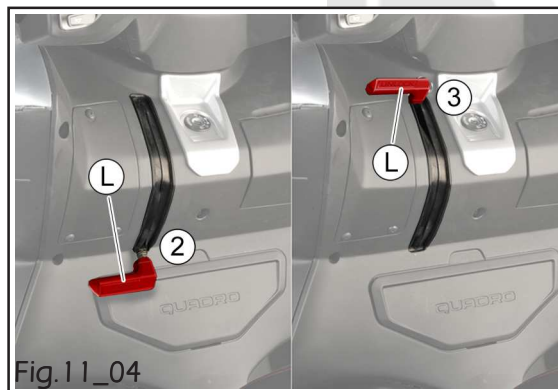

VEHICLE DESCRIPTION

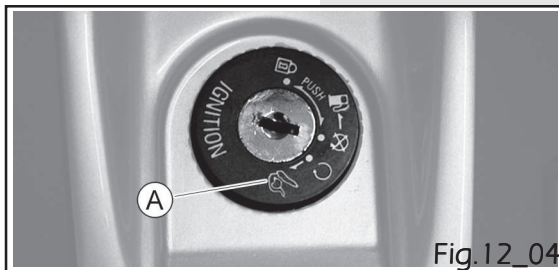

4.16 HELMET COMPARTMENT

To gain access to the helmet compartment, proceed as follows:

- Use your key to rotate the ignition switch clockwise up to the seat opening position «A» .
- Lift the seat.
- Access the helmet compartment.

The helmet compartment can fit two full-face helmets;

To close the seat, proceed as follows:

- Lower the seat and press down at the rear to engage in the seat lock.



4.17 FRONT GLOVE BOX

To gain access to the front glove box «G», press in the point shown in the figure and open the glove box flap.

Maximum load: 1,5 kg

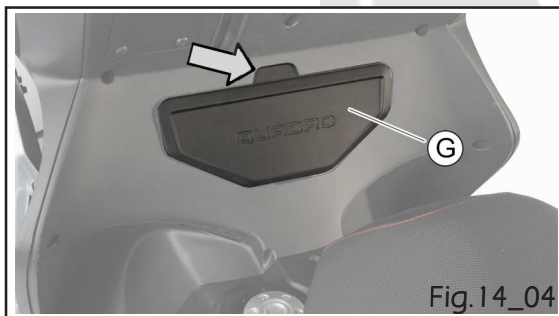



VEHICLE DESCRIPTION

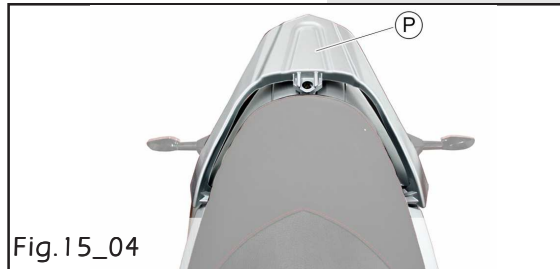

4.18 REAR LUGGAGE RACK

This vehicle is fitted with a luggage rack «P» which allows you to fit an approved top case. Under any circumstance, the maximum loading may not be exceeded (fig. 15_04).

Maximum load: 5,0 Kg

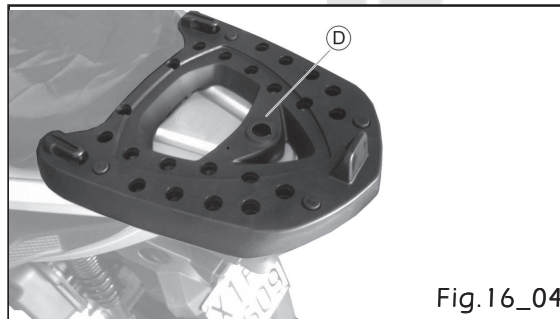

4.19 TOP CASE

An approved top case «B» may be fitted to the vehicle for greater loading capacity.

When installing the top-case, you must use the mounting plate «D» provided and follow the enclosed fitting instructions (fig. 16_04).

To open the top case, proceed as follows:

- Using your case key, turn the lock «E».
- Press the release button «F» and lift the top half of the case.



VEHICLE DESCRIPTION

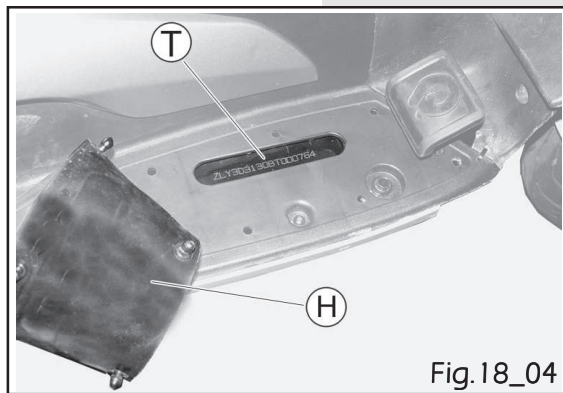

Fig.18_04

4.20 SERIAL NUMBERS

This vehicle may be identified via two unique numbers: the Vehicle Identification Number (VIN) and the Engine Serial Number.

- The Vehicle Identification Number «T» (VIN) (fig. 18_4) is stamped on the frame's right hand crossbeam and it may be accessed by removing the passenger's footrest «H».
- The Engine Serial Number «R» (fig. 19_04) is stamped on the engine crankcase.

For future reference, record your vehicle's serial numbers in the spaces provided below.

VEHICLE IDENTIFICATION NUMBER:

--	--	--	--	--	--	--	--	--	--	--	--	--	--	--	--	--	--	--	--	--

ENGINE SERIAL NUMBER:

--	--	--	--	--	--	--	--	--	--	--	--	--	--	--	--	--	--	--	--	--

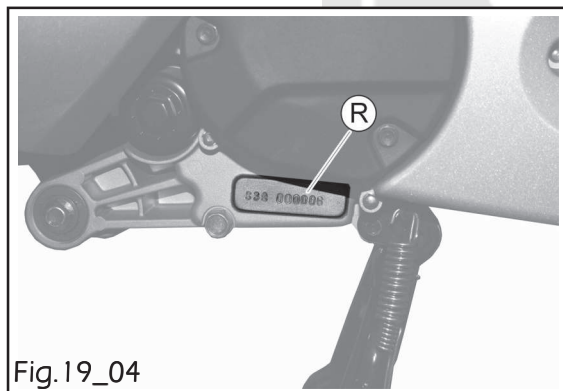

Fig.19_04



Tampering with your vehicle's serial numbers is punishable by law and your vehicle's warranty will become void immediately.



VEHICLE DESCRIPTION



4.21 CENTRE STAND

Push the stand's bracket «17» downwards with your foot, whilst easing the vehicle backwards until it rests safely onto its centre stand.



Do not sit on the vehicle when it is resting in its centre stand.



Always park on a firm, level surface to prevent the vehicle from falling.

Do not lean the vehicle against walls or road signs.



4.22 EXHAUST SYSTEM

This vehicle's exhaust system is fitted with a catalytic converter «6». Owners are warned that the law may prohibit:

- The removal or rendering inoperative by any person other than for purposes of maintenance, repair or replacement, of any device or element of design incorporated into any new vehicle for the purpose of noise and emission control and,
- The use of the vehicle after such device or element of design has been removed or rendered inoperative by any person.

VEHICLE DESCRIPTION



Inspect your vehicle's exhaust system regularly in order to ensure that it is functioning correctly and that it shows no sign of rust or cracks/holes. Please contact an authorised service centre in the event that the noise level or smoke produced by the exhaust increase.



Tampering with the Exhaust System is strictly Prohibited.

4.23 REAR VIEW MIRRORS

To fit the rear view mirror, slide into place and tighten and tighten the nut as shown in the figure (fig.22_4). Once secured, adjust the mirror so that it suits your riding position.

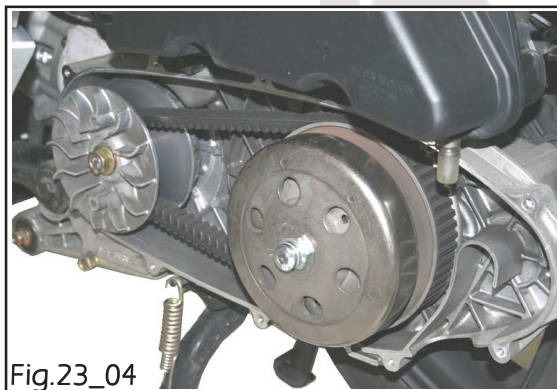

4.24 AUTOMATIC TRANSMISSION

In order to offer the most comfortable and seamless riding experience, this vehicle has been fitted with an automatic transmission, designed with performance and fuel economy in mind. The transmission consists of an automatic centrifugal dry clutch, a rubber V-belt and an automatic variable pulley system



In the event of a hill start, or when queuing up in traffic or at traffic lights, you must use the brakes to hold the vehicle while letting the engine run at idle. Using the engine to hold the vehicle will cause the clutch to overheat resulting in an early wear of its components.

VEHICLE DESCRIPTION

It is highly recommended that you avoid riding your vehicle in a way that will stress the clutch components over long periods of time and that will cause them to overheat, e.g. riding uphill on a steep incline with a full load, or attempting a hill start with a passenger on a road with a 25% slope or higher: In case of clutch overheating, allow the clutch to cool down for a few minutes with the engine running at idle.

4.25 HYDRAULIC TILTING SYSTEM (HTS)

This vehicle has been fitted with a hi-tech hydro-pneumatic suspension system known as **HTS (Hydraulic Tilting System)**, which is protected by international patents and that guarantees stability, manoeuvrability, safety and fun.

This innovative hydraulic suspension system automatically allows both wheels to constantly adjust to the road surface without requiring riders to modify their riding position thus ensuring a stable and comfortable ride even in situations that may set a normal vehicle off balance (e.g. road humps and dips, rails, unexpected obstacles, etc.). This innovative tilting mechanism allows the vehicle to deliver the highest levels of performance, comfort, and enjoyment in complete safety.

The Hydraulic Tilting System (**HTS**) is fitted to the front wheels allowing them to tilt or bank simultaneously and trail independently. Compared to the various mechanical systems currently on the market, the HTS distinguishes itself for its ease of use and for its simple design, which result in a lower weight and minimal maintenance.

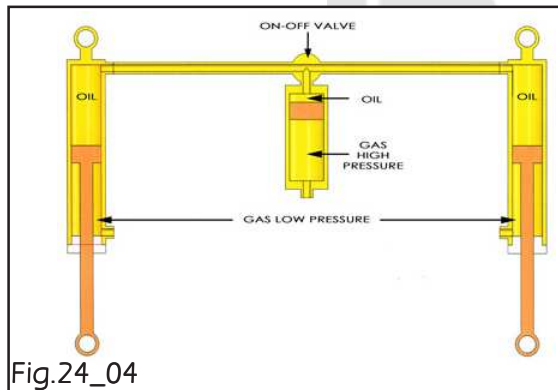

The Hydraulic Tilting System (**HTS**) consists of two “hydraulic” cylinders and a single “spring” cylinder. The hydraulic cylinders connect the vehicle’s frame to the two front wheel swinging-arms, while the centrally-mounted spring cylinder provides the traditional dampening effect for the front suspension.

The oil flow through all cylinders is regulated by a valve according to the movements deriving from the roughness of the road surface and the lean.

In addition, the compressed gas stored in the lower section of the hydraulic cylinders helps increasing the front wheels’ response to the rider’s commands, thus improving manoeuvrability from standstill, and providing higher riding stability and safety. All of this brings unparalleled braking and handling performance.

VEHICLE DESCRIPTION



Do not remove the caps from either of the two cylinders. Removing the cap will result in a gas leakage and will damage your vehicle's HTS.



Do not remove the cap «1» located on the centrally-mounted spring cylinder. Removing the cap will result in a gas leakage and will damage your vehicle's HTS.

Clean the chromed parts of the cylinders periodically and apply a coat of suitable protective product.

4.26 SHOCK ABSORBER ADJUSTMENT

The vehicle's rear shock absorbers are fitted with a preload adjuster. Tighten or loosen the ring nut «G» to adjust the suspension's settings in order to maintain an optimal riding set-up with different loadings. The lowest position corresponds to the maximum preload (rider + passenger + luggage), The highest position corresponds to the minimum preload (rider only).



Riding the vehicle with an incorrect preload can reduce the ride comfort and precision. Adjust both shock absorbers to the same preload.



To avoid any risk of abrasion use suitable gloves when adjusting the shock absorber.



Quadro 350D



CHAP.5 RIDING THE VEHICLE





RIDING THE VEHICLE

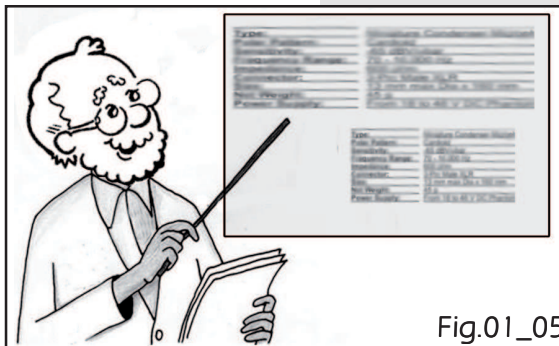

Fig.01_05

5.1 PRELIMINARY CHECKS



The following checks must always be carried out before riding the vehicle in order to ensure its trouble-free operation. Failure to comply with this rule may lead to serious injuries and damage to the vehicle.

Engine oil	Check the level (pag.58)
Final drive oil	Check the level (pag.61)
Water cooled	Check the level (pag.69)
Braking system	Check that the braking levers do not stick while operating. Check the front disc brake oil level (pag. 70), and that there is no leakage in the circuit. Check the rear drum brake adjuster tightening (pag. 72).
Throttle control	Check the correct opening/closure operation during the whole handlebar rotation
Lights, warning lights, horn, turn indicators	Check the right operation of visual and acoustic devices
Steering wheel	Check that the rotation is homogeneous, smooth and play-free
Tyres	Check the tyres right inflation pressure, wear state, and any possible damage
Central / side stand	Check that it operates properly, i.e. the springs bring it to the rest position
Fuel tank	Check the fuel level, any leakage and its correct closure
Tightening elements	Check that the tightening elements are not slackened
Hydraulic Tilting System (HTS)	Ensure that the caps are (see fig. 24_04) and that there are no leaks within the circuit.



RIDING THE VEHICLE

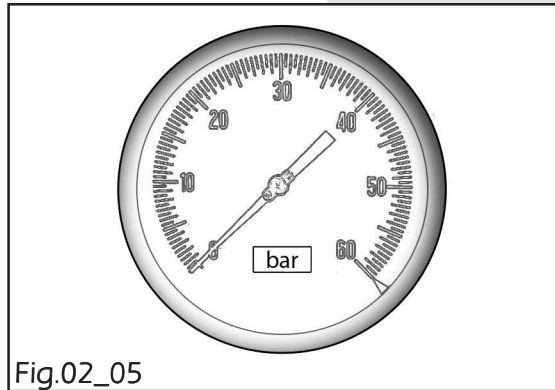

Fig.02_05

5.2 TYRES INFLATION PRESSURES

Correct inflation pressure will provide maximum stability, rider comfort and tyre life. Always check tyre pressures before riding when the tyres are cold.

Front tyre pressure: 1,5 bar (22 Psi)

Rear tyre pressure: 2,2bar (32,3 Psi) single driver 2,5 bar (36,2 Psi) with passenger



WARNING ATTENTION

Tyre pressures must always be checked when the tyres are cold. Incorrect tyre inflation will cause abnormal tread wear and instability problems that may lead to loss of control and an accident resulting in serious damages and injuries.

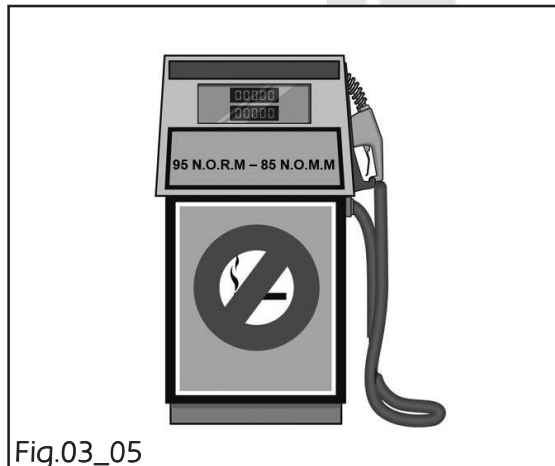

Fig.03_05

5.3 REFUELLING

Follow the procedure described in the «Vehicle Description/Fuel Tank» section of this handbook to access the fuel tank and refuel your vehicle using exclusive 95 RON unleaded fuel.

Fuel Tank Capacity: approx. 13 l - reserve: approx. 3 l.



During refuelling, the ignition switch must be in the OFF position. Petrol (fuel) is highly flammable; do not smoke; keep away from any source of flames; do not inhale petrol fumes.



ATTENTION

To prevent any damage, ensure that petrol does not spill onto the plastic fairings of the vehicle.



RIDING THE VEHICLE



Do not ride the vehicle until it runs out of fuel. Should this occur, do not attempt to restart it. Turn the ignition switch to the "OFF" position and refill the fuel tank as soon as possible. Failure to do so may damage the fuel pump and/or the catalytic converter.



Do not use any type of fuel other than the recommended one as this would reduce the efficiency of the exhaust system and fuel supply.

5.4 STARTING THE ENGINE

Once all checks described in the «Riding the Vehicle/Preliminary Checks» section have been carried out, you may proceed to start engine as follows:

- Place the vehicle on its centre-stand with the rear wheel lifted off the ground and release the parking brake lever "L" lowering it from «2» to «3» (fig. 04.05).
- Insert the key in the ignition switch and rotate it to «ON» (fig. 04.06).
- Keep the throttle control in the closed position.
- While pulling the front brake lever press the starter button as shown in (fig.04_07).



Never start the engine without its airbox. Dust or foreign objects may enter the engine, damaging it.

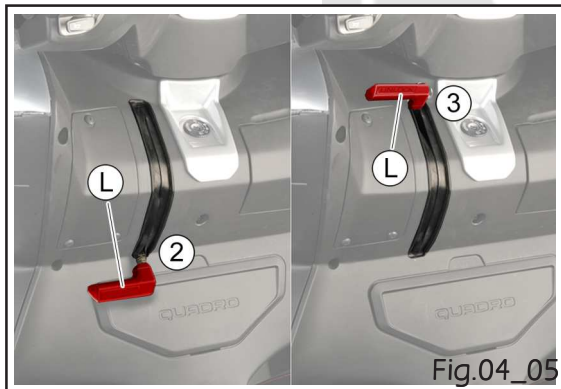



RIDING THE VEHICLE

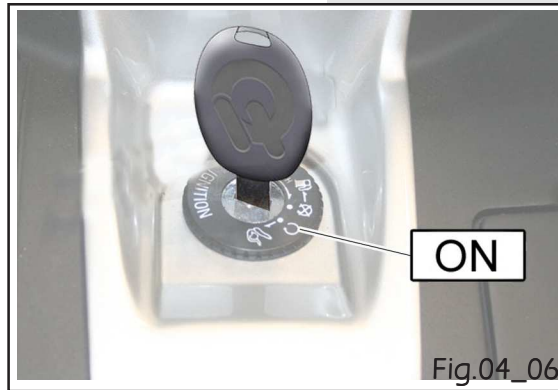

Fig.04_06



After starting the engine ride at moderate speeds during the first few minutes. A correct engine warm-up limits the emissions and reduces fuel consumption.



In parking areas, pay particular attention that the silencer does not come into contact with flammable material or body parts. The high temperature can cause fires and/or burns.



ATTENTION

To prevent damage, do not rev up the engine when cold. To safeguard the integrity of the engine and its duration lasting performance, avoid riding at high revs for long periods of time.



ATTENTION

Do not suddenly switch off the vehicle after riding for a long time at the maximum speed; let it run at idle for a few seconds.

If you are starting your vehicle for the first time after a long period of inactivity, follow the operations described under the section «Vehicle Maintenance/Vehicle Storage»



ATTENTION



WARNING

Exhaust gases are highly toxic; do not start the engine indoors or in poorly ventilated areas.



WARNING

Do not attempt to start the vehicle with throttle fully opened. This could lead to a loss of control of the vehicle resulting in possible injuries and damage.

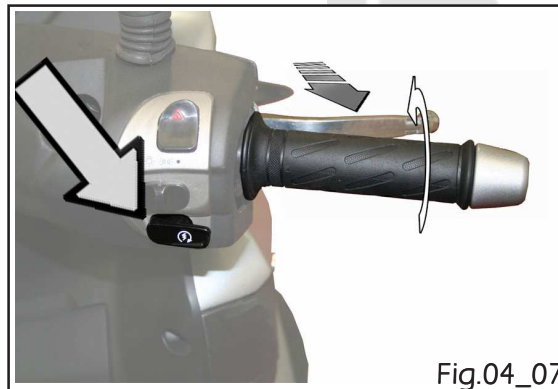
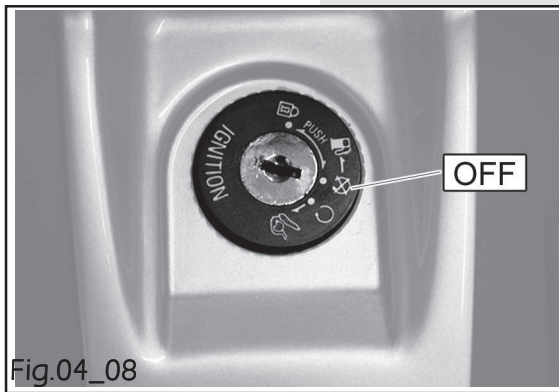



Fig.04_07

RIDING THE VEHICLE



5.5 STOPPING THE ENGINE

Bring the vehicle to a halt and rotate the ignition switch to the «OFF» position .

With the ignition switch in this position, it is not possible to start the engine, the key may be removed and the steering lock is not engaged.



Do not rotate the ignition switch to «OFF»  while riding. Unburnt fuel may damage the catalytic converter.

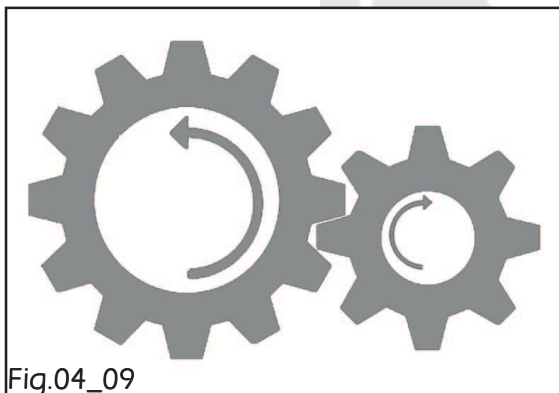

5.6 RUNNING-IN



A period of careful running-in will ensure the longevity of the engine.



YOU MUST ALWAYS HAVE YOUR VEHICLE UNDERGO THE FIRST AND MOST IMPORTANT SCHEDULED SERVICE



RIDING THE VEHICLE

The first 1,000 km represent the most critical period in the life of your vehicle. A period of careful running-in will optimise the performance, and longevity of the engine and other components. All **Quadro** parts have been built using the highest quality materials and have been machined with minimal tolerances. A correct running-in allows all components to 'bed-in' thereby reducing internal frictions.

The reliability and performance of your vehicle depend on how strictly you follow the instructions provided within this section. It is important that you prevent the engine from overheating.

- During the first 500 km (300 miles), do not exceed $\frac{1}{2}$ of throttle and limit your speed to 80 km/h (50 mph)
- From 500 to 1,000 km (600 miles), do not exceed $\frac{3}{4}$ of throttle and limit your speed to 100 km/h (60 mph)

Engine speed must be varied constantly and it must not be allowed to remain constant for a long period of time. This ensures that engine components are not being excessively stressed, thus allowing them to cool down and to bed-in properly. You must always ensure that engine components are not being overstressed by avoiding high engine speeds.

The first service, at the 1,000 km (600 miles) mark, is the most important one for your vehicle. During running-in all components will bed-in, thus requiring all adjustments to be checked, all fixings to be tightened and engine oil to be replaced.

Performing such operations as soon as possible after the first 1,000 km (600 miles) will ensure the longevity and optimal performance of your engine.

NB: The 1,000 km (600 miles) service must be carried out according to the "Scheduled Maintenance" section of this handbook. Please pay particular attention to the warnings provided within the section.



RIDING THE VEHICLE

5.7 SAFE OPERATION

This section provides you with a number of key tips to ride your vehicle safely. You must become familiar with these suggestions and must adhere strictly to your local traffic laws as well as all warnings which have been summarised in this handbook, as these constitute the basis for a safe ride.

- Carefully read all instructions contained in this handbook.
- We recommend that you first familiarise yourself with your vehicle in areas with limited or no traffic in order.
- Always wear a helmet and ensure that it is correctly fastened before riding.
- Reduce your speed when riding on uneven roads or in the presence of strong winds.
- Operate the brakes frequently when riding on wet roads as such conditions greatly reduce the efficiency of the braking system.
- Clean all brake discs frequently if you ride over dusty, muddy, or snowy roads.
- Do not adjust the rear view mirrors while riding as this may result in the loss of control of the vehicle.
- Never ride your vehicle when fatigued or under the influence of alcohol or other drugs.
- The addition of accessories and carriage of additional weight can affect the vehicle's handling characteristics; ride carefully.
- Do not pull away while sitting on the vehicle.
- Strictly observe your local traffic laws.
- Tuning your vehicle or altering any of its original parts is prohibited by law and it makes the vehicle non-conforming to the homologated type and thus dangerous to ride.



ATTENTION

Do not ride over steps or pavements. The impact may damage the suspensions.



Quadro 350D



CHAP.6 VEHICLE MAINTENANCE





MAINTENANCE VEHICLE

6.1 GENERAL

To maintain your vehicle in a safe and reliable condition, the maintenance and adjustments outlined in this section must be carried out in line with the scheduled maintenance chart.



WARNING



ATTENTION

Special tools, knowledge and training are required in order to correctly carry out the maintenance items listed in the scheduled maintenance chart.



WARNING



ATTENTION

Only an authorised service centre or dealer will have this knowledge and equipment.



WARNING

All maintenance operations must be performed with the engine off, with the vehicle resting on its centre stand and with the parking brake engaged.



WARNING

Do not neglect maintenance as the efficiency and longevity of your vehicle strictly depend on how it is being maintained.



WARNING

All maintenance operations, with the exception of idle adjustments, must be carried out with the vehicle in a stationary position. Make sure no one interferes during idle adjustment.

When performing maintenance operations you must strictly follow the safety instructions outlined in paragraph 6.2.

Any kind of temporary repair is strictly forbidden.

All controls and devices must be checked after any maintenance operation.

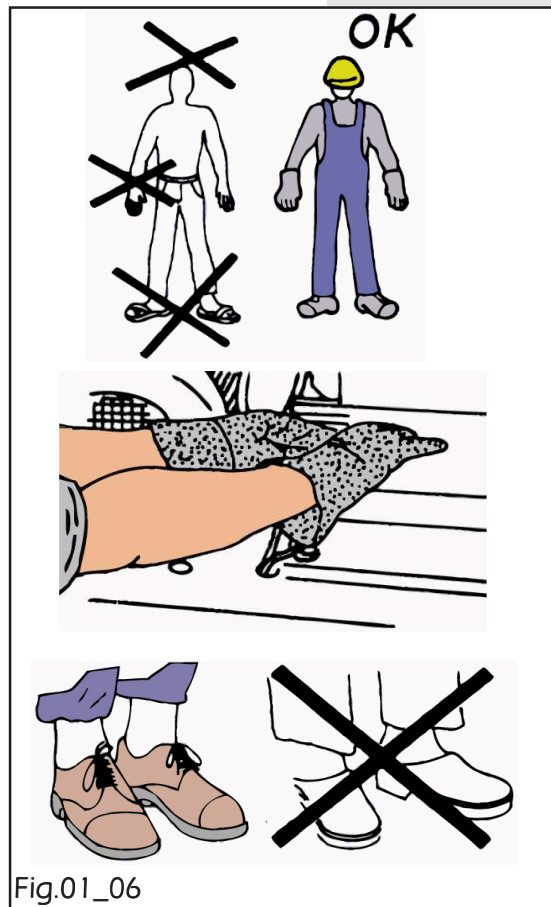

6.2 SAFETY INSTRUCTIONS FOR MAINTENANCE

All maintenance operations performed on the vehicle must be compatible and carried out in observance with the specific safety standards.

Remove any item that may cause injury (watches, bracelets, rings, etc.).



Wear appropriate clothing (overalls or shirts with elastic cuffs) or roll up your shirt sleeves up to prevent them from getting entangled.



Wear safety gloves



Wear safety shoes

Before setting out to perform any maintenance operation you must ensure that you are in good health and are not under the influence of alcohol or any other drugs.



MAINTENANCE VEHICLE

6.3 DAILY CHECKS

Before riding your vehicle, always perform the following checks:

- Check coolant level
- Check engine and final drive oil levels
- Check fuel tank level
- Check tyre pressure
- Ensure that fuel tank cap is tighten correctly
- Ensure that all brake hoses are not obstructed, that there are no leaks, and that the brake callipers are clean
- Check brake fluid levels
- Check engine idle speed
- Check that the throttle grip returns to idle position without sticking

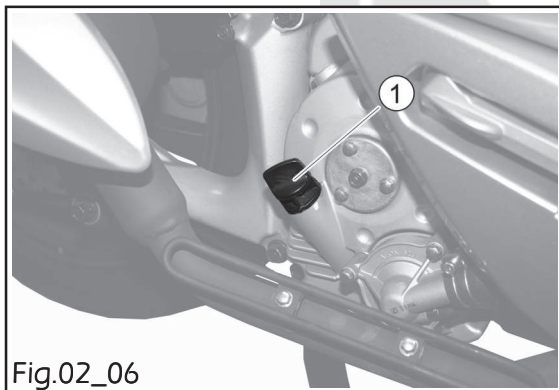

Fig.02_06

6.4 ENGINE OIL

Engine oil: SAE 10W - 60 API- SJ (1,7)

Engine oil level checks, top ups and replacement must be carried out in accordance with the scheduled maintenance chart.



WARNING

Prolonged or repeated contact with engine oil can lead to injuries; always wear protective clothing and carefully wash off any used oil that has come into contact with your skin. Keep engine oil away from the reach of children.

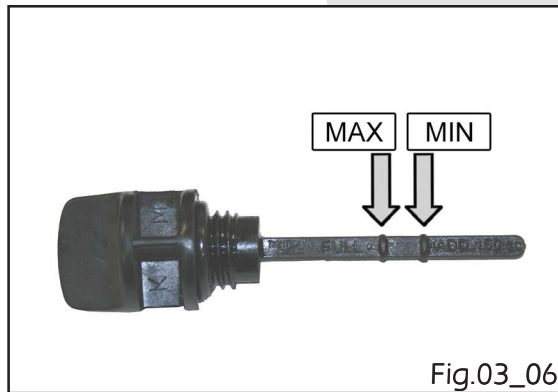

Level Checks

- Wait for 5 minutes after switching off the engine.
- Rest the vehicle on its centre stand and on level ground.
- Loosen and remove the filler plug/dipstick «1» and dry it with a clean rug.
- Refit and tighten the filler plug/dipstick «1» (fig. 02_06).
- Loosen and remove the filler plug/dipstick «1» for a second time and check that the oil level is now between «MIN» and «MAX» marks as show in the figure (03_06)



ATTENTION

Running the engine with insufficient or contaminated oil will cause engine damage. If the low oil pressure indicator remains on, stop the engine immediately.

Top up

Any oil top up must occur only after level check.

If the oil level is below the **MIN** marking, add oil a little at a time through the filler plug hole until the correct level is reached.

For top ups, proceed as follows:

- Remove the filler plug/dipstick and add oil.
- Check that the oil level is between the «MIN» and «MAX» marks (see figure 03_06).

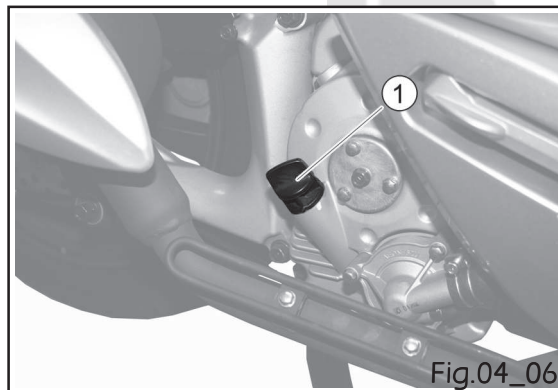

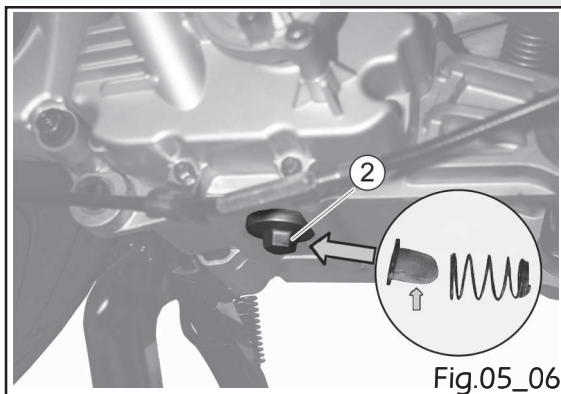

Replacement

- Warm up the engine for approximately 5 minutes, then switch off.
- Loosen and remove the filler plug/dipstick «1» (see fig.04_06 pag.57).
- Loosen and remove the oil drain plug «2». The spring and oil strainer screen (see fig. 05.06), will come out with the drain plug. Remove the oil filter cartridge «F» and replace with a new oil filter.
- Clean the oil strainer screen (see fig. 05.06), refit together with the spring and the drain plug «2», then tighten to the specified torque.
- Fill the engine with approximately 1,7 l of the recommended engine oil.
- Check the oil level and top up until the minimum oil level has been reached.

Tightening torque specifications (Nm)

Oil drain plug: 15



Oil may be hot, pay attention.



Do not disperse used oil in the environment.
Disposal of engine oil is regulated by law.



It is highly recommended that you have these operations performed by an authorised service centre or qualified personnel.

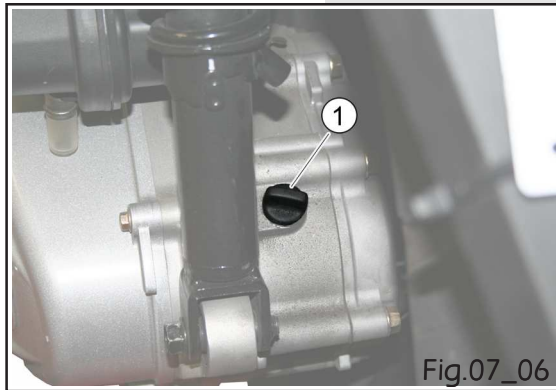

6.5 FINAL DRIVE OIL

Final drive oil level checks, top ups and replacement must be carried out in accordance with the scheduled maintenance chart (pag. 77).



ATTENTION

Let the engine cool down before carrying out any maintenance operation.

Level Checks

- Rest the vehicle on its centre stand and on level ground.
- Loosen and remove the filler plug «1» and check that oil spills out or reaches the edge of the filler hole; if so, then the level is correct.
- Otherwise, top up using recommended oil.

Replacement

- Position a suitable container directly underneath the drain hole.
- Remove the filler plug «1» and store the washer away.
- Unscrew the drain plug «2», store the washer away and drain all oil.
- Refit and tighten the drain plug «2» and using a syringe fill up to the correct level with the recommended oil type.

Final drive oil: SAE 80W-90 (180 cm³)



Oil may be hot, pay attention.



Always dispose of used oil responsibly. For its disposal, please observe your local regulations.

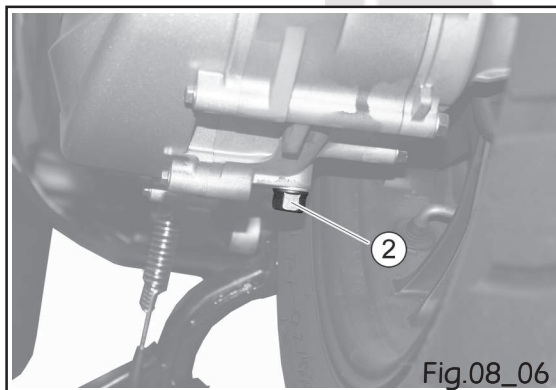

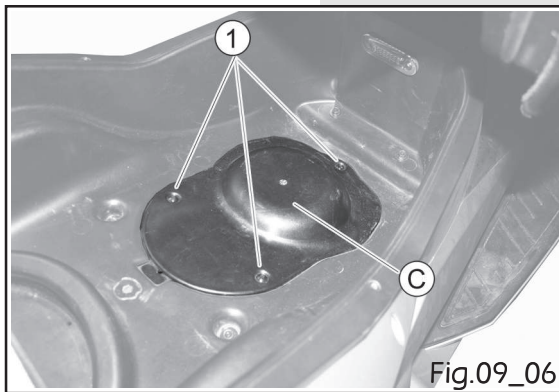

6.6 SPARK PLUG



Let the engine cool down before carrying out any maintenance operation.

The spark plug must be inspected and replaced in accordance with the scheduled maintenance chart (see pag. 77).

- Rest the vehicle on its centre stand and on level ground.
- Lift the seat, remove the three fixing screws «1» and lift the inspection flap «C».
- Release the plug cap «2» from the plug's terminal, (see fig. 10_06).
- Remove the spark plug «3» using a box spanner, (see fig. 11_06).
- Clean off any dirt and carbon residue from the spark plug. Check the spark gap.
- Manually screw the spark plug in its seat
- Carefully refit the spark plug cap «2».

Recommended Spark plug: NGK DPR7EA-9

Spark gap: 0.6 ÷ 0.7 mm

Tightening torque specifications (Nm)

Spark plug: 10 ÷ 20

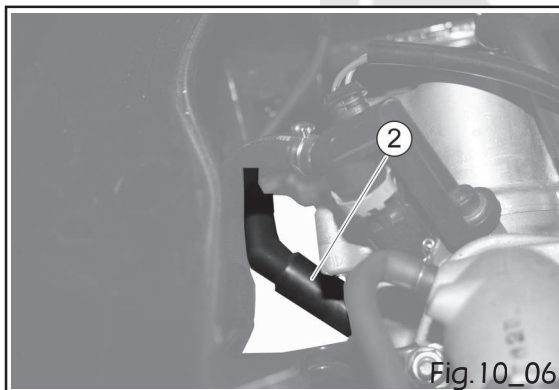



MAINTENANCE VEHICLE

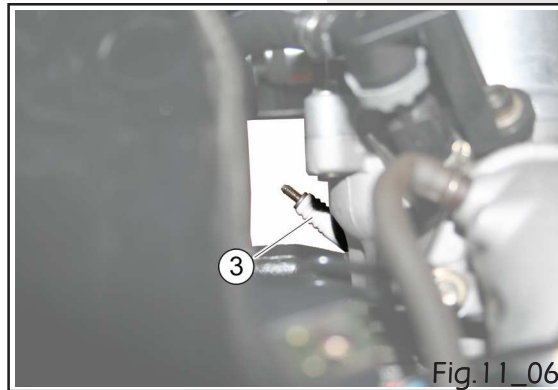

ATTENTION

To prevent engine damage, only use spark plugs of the recommended type.



WARNING



ATTENTION

It is highly recommended that you have these operations performed by an authorised service centre or qualified personnel

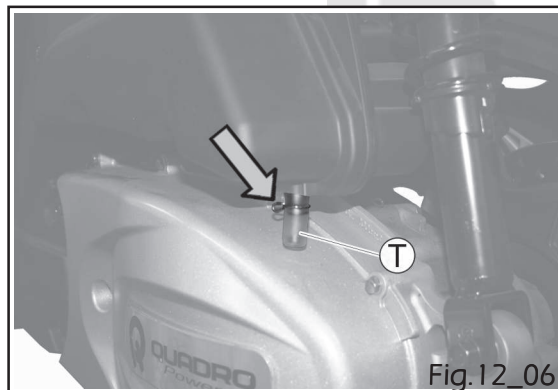

6.7 DRAINING EVAPORATED OIL

Position a suitable container directly underneath the airbox.

Remove the circlip shown in the figure.

Remove the cap «T» and empty out all oil which has accumulated inside it.

Dispose of the oil in an environmentally friendly manner and in accordance with local regulations.



WARNING



ATTENTION

It is highly recommended that you have these operations performed by an authorised service centre or qualified personnel.

MAINTENANCE VEHICLE

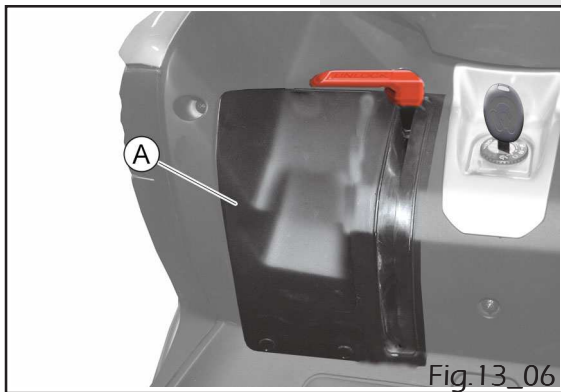

6.8 BATTERY



WARNING



ATTENTION

When removing the battery, the engine must be off and the ignition key must not be in the ignition switch.

Removal

To replace the battery, proceed as follows:

- Rest the vehicle on its centre stand and on level ground.
- Ensure that the ignition key is not inserted into the ignition switch.
- Remove battery cover «A» by loosening the two screws below and release the three upper side tabs.
- Disconnect the leads «1» starting from the negative lead «-» followed by the positive «+».
- Loosen the screw shown and remove the retaining bracket «B».
- Remove the battery.



WARNING

Do not disconnect the battery leads with the engine running.



Always dispose of old batteries responsibly. For their disposal, please observe their local regulations.

Check

Ensure that the battery leads and terminals are not excessively corroded. If necessary, use a wire brush to clean them.

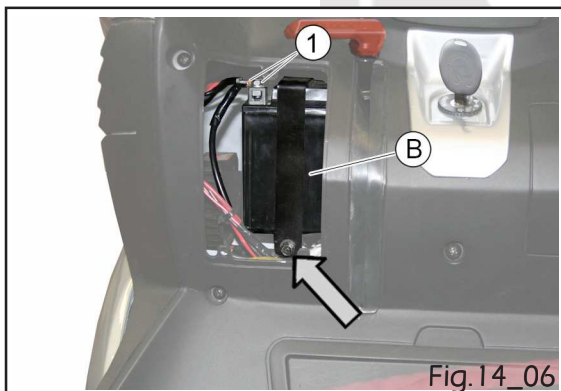



Installation



WARNING

Do not swap the battery leads. Reconnect the battery, positive lead first.

- Place the battery in the battery case.
- Reconnect the positive lead «+» and then the negative lead «-».
- Apply a light coat of grease to the terminals to prevent corrosion.
- Refit the retaining bracket «B» and secure it with the fixing screw (see fig.14_06).

Battery: 12V – 12 Ah

Battery Charging



ATTENTION

This vehicle is fitted with a sealed (maintenance-free) battery. Only use a suitable charger.



ATTENTION

Do not attempt to remove the cell caps as this may damage the battery.

- Extract the battery from its case.
- Connect the battery to a suitable charger and set it to “slow-charging” mode.
- Recharge the battery with a current equal to 1/10 of the battery’s rating for no longer than 10 hours.

Battery voltage: 12V



WARNING



ATTENTION

It is highly recommended that you have these operations performed by an authorised service centre or qualified personnel.

MAINTENANCE VEHICLE

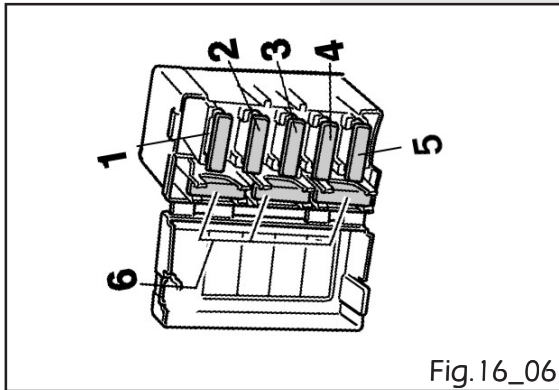

Fig.16_06

6.9 FUSE BOX

To allow access to the fuse box, turn the ignition switch to the seat opening position, lift the seat and remove the helmet compartment.



Before replacing a blown fuse, you must ensure that the problem has been fixed and must not attempt to fix the fuse. Only use fuses of the specified rating.

1. 30A Protected Circuits
2. 15A Main
3. 10A Lights
4. 10A EFI
5. 5A Ignition
6. Spare

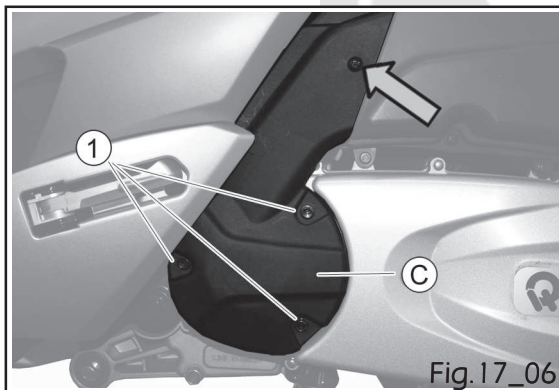

Fig.17_06

6.10 AIRBOX



Let the engine cool down before carrying out any maintenance operation.

Your vehicle's airbox must be cleaned in line with the scheduled maintenance chart.

Removal

- Remove the three fixing screws «1».
- Remove the screw shown in the figure.
- Remove conveyor «C».

MAINTENANCE VEHICLE

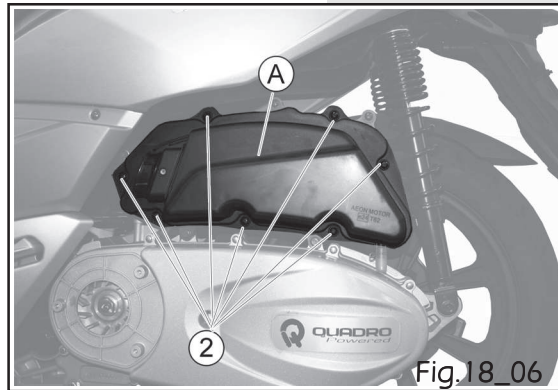

- Release the passenger foot-peg and remove the screw.
- Pull the cover «P» outwards in order to ease the removal of the duct (see fig. 17_06).
- Remove the duct «C» (see fig. 17_06).
- Remove the seven screws «2», which the airbox cover in place.
- Remove the airbox cover «A».

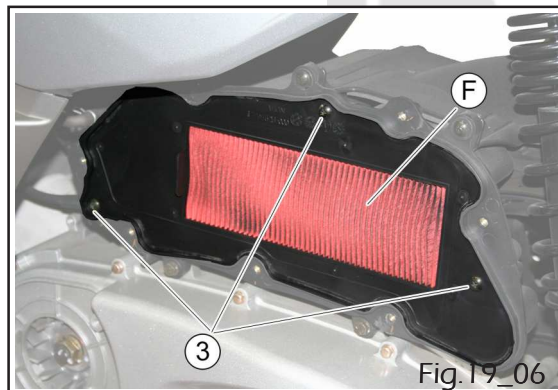

- Remove the three air filter retaining screws «3».
- Remove the air filter «F» (see fig. 19_06).



ATTENTION

This operation should be carried out more frequently if you often ride your vehicle over dusty or wet roads.

MAINTENANCE VEHICLE



CLEANING



WARNING

DO NOT USE PETROL OR OTHER FLAMMABLE LIQUIDS TO CLEAN YOUR AIR FILTER.

- Gently brush any dirt off the surface with a clean rug.
- Blow compressed air from the inside out, in the direction shown in the figure.

Refit the airbox following the above procedure in reverse order.



WARNING



ATTENTION

It is highly recommended that you have these operations performed by an authorised service centre or qualified personnel.

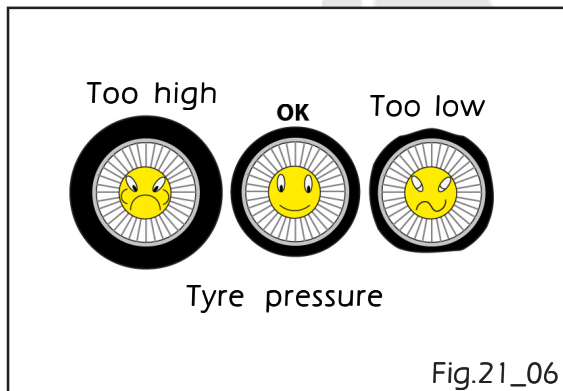

6.11 TYRES

The tyre inflation pressure (Fig. 21_06) must be checked periodically before riding.

Front tyre: Tubeless 110/80-14 53 P

Rear tyre: Tubeless 140/70-15 69 P

Front tyre pressure: 1,5 bar (22 Psi)

Rear tyre pressure: 2,3 bar (32,3 Psi) single driver - 2,5 bar (36,2 Psi) with passenger

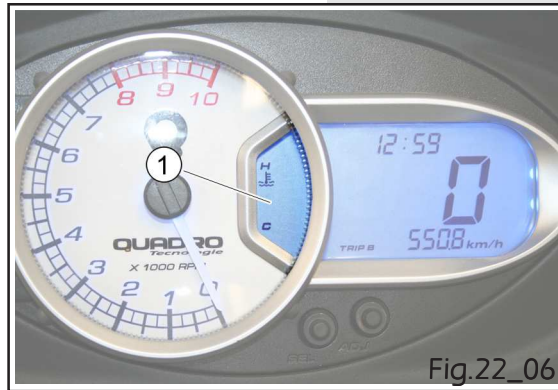

Fig.22_06

6.12 COOLANT

This cooling system is fitted with an electric fan (which starts automatically above a given temperature) in order to guarantee the most efficient performance in all riding conditions. The fluid used as coolant is constituted by a liquid solution of ethylene glycol-based antifreeze and corrosion inhibitors. In order for the correct operating temperature of the engine to be maintained, the indicated coolant temperature must remain in the bottom half of the gauge «1». If the bars in the top-half of the gauge «1» illuminate while riding the vehicle, stop the engine immediately and allow it to cool down. When it is safe to do so, check the coolant level and if necessary contact an authorised service centre.



WARNING

Always ensure that the coolant level within the expansion tank does not exceed the maximum mark.



WARNING

Let the engine cool down before carrying out any maintenance operation.

Level Checks

You must always check the coolant level with the engine cold and in accordance with the scheduled maintenance chart.



ATTENTION

In order to ensure the optimal operation of the engine, always check that the radiator grill is clean.

To check the coolant level, proceed as follows:

- Rest the vehicle on its centre stand and on level ground.
- Through the inspection hole «3» located underneath the footrest check that the coolant level reaches the **Top** mark.

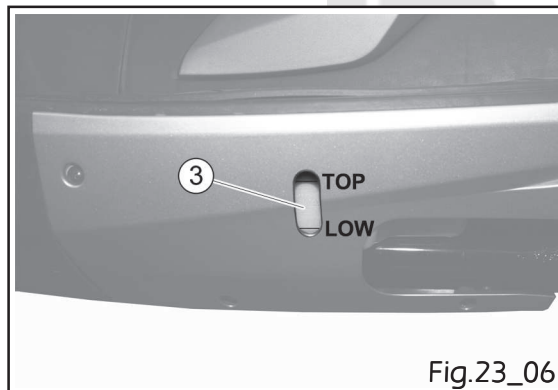

Fig.23_06



MAINTENANCE VEHICLE

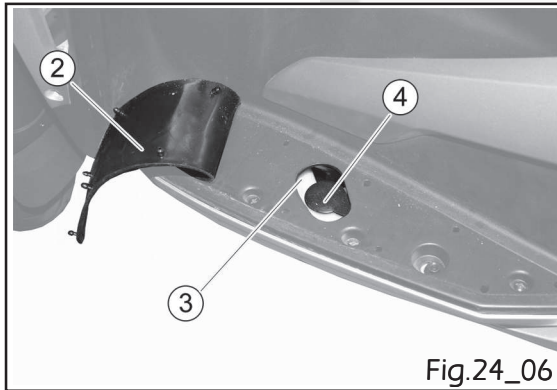

Fig.24_06

TOP UPS



To avoid burns, do not remove the expansion tank filler cap when the engine is still hot.

If the coolant level drops below the TOP mark, allow the engine to cool down, lift the footrest mat «2», and remove the expansion tank «3» filler cap «4».

Coolant fluid: CUNA NC 956-16

If you find yourself having to frequently top up the coolant level, you must have an **Authorised Service Centre** carefully inspect your vehicle's cooling system.

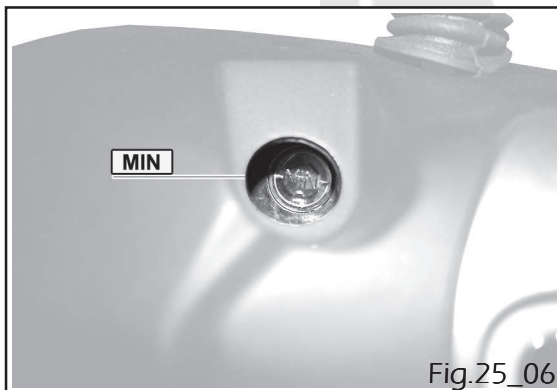

Fig.25_06

6.13 BRAKE FLUID

Level Checks

You must always check the brake fluid level before riding and in accordance with the scheduled maintenance chart (see page 77). Please note that the level of the fluid inside the reservoirs will decrease progressively as the brake pads wear out.

Before topping up with new brake fluid, check the lining thickness of the brake pad. If this is found to be below the minimum, please contact your nearest Authorised Service Centre.

Rest the vehicle on its centre stand and on level ground.

Ensure that the brake fluid level is never below the minimum level marking.

MAINTENANCE VEHICLE

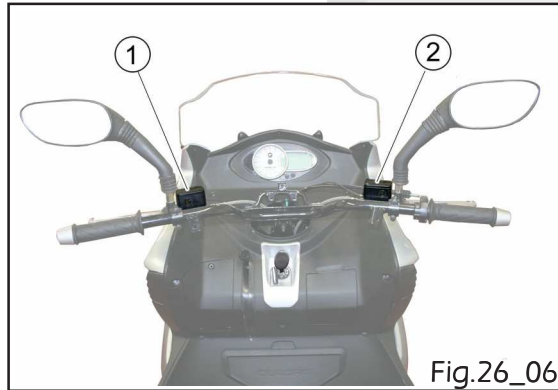

The brake fluid reservoirs are located on the handlebar; to allow access to them, you must remove the aft handlebar cover.

The combined (front and rear) brake reservoir «1» is located on the left-hand side, while the front brake reservoir is found on the right hand side «2» of the handlebar.



WARNING

Brake fluid is highly corrosive. Avoid any contact with the skin and the eyes. In the event of accidental contact, rinse thoroughly with water. Keep away from the reach of children.



ATTENTION

Check the brake hoses for splits, deterioration and damage. Always ensure that the brake discs are not worn and/or greasy.

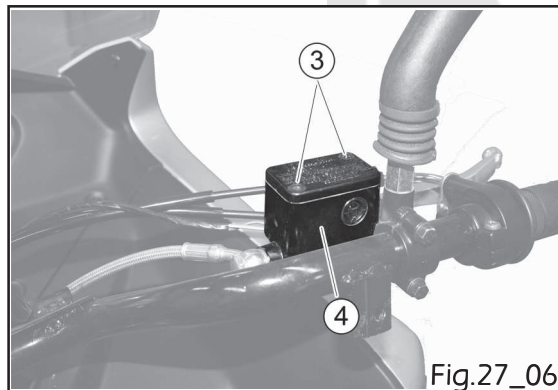

TOP UP

- Remove the front handlebar cover.
- Release the two reservoir cap screws «3» and detach the cover «4» and sealing diaphragm.
- Top up with new DOT4 brake fluid from a sealed container.

Brake fluid: DOT4



WARNING

ATTENTION

Do not disperse used brake fluid in the environment. Disposal is regulated by law.

It is highly recommended that you have these operations performed by an authorised service centre or qualified personnel.



MAINTENANCE VEHICLE

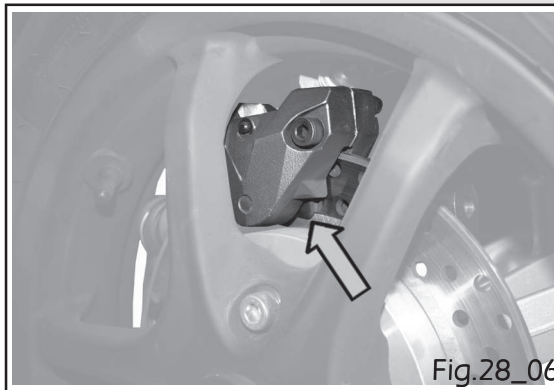

6.14 FRONT AND REAR BRAKE DISCS



To guarantee your safety, the braking system must always be kept in perfect working conditions.



The longevity of brake pads is significantly reduced by dust, mud, etc.



It is highly recommended that you have these operations performed by an authorised service centre or qualified personnel.

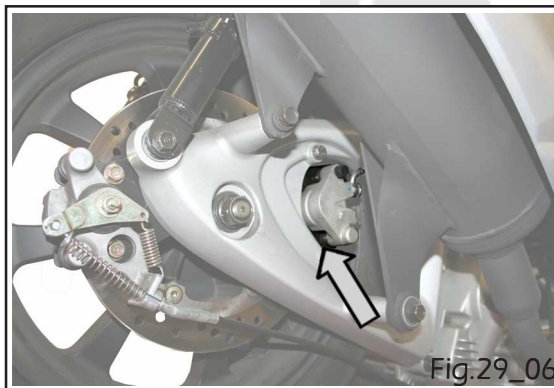

Brake Pads

Brake pads must be inspected in accordance with the scheduled maintenance chart (see pag. 73 and 77)

In order to check the thickness of the brake pad lining, proceed as follows:

- Rest the vehicle on its centre stand and on level ground.
- Check the thickness of the brake pad lining from the front of the vehicle and leaning underneath the brake calliper.



MAINTENANCE VEHICLE

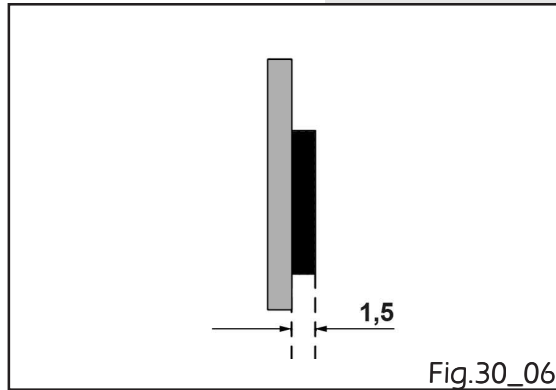

If the lining thickness of any pad is less than 1.5 mm (0.06 in), replace all the pads on the wheel.



Riding with brake pads worn beyond the limit stated above may cause the pad itself to come into direct contact with the brake disc, damaging the disc.



Do not ride the vehicle immediately after replacing the brake pads. You must first apply the brake lever several times until the calliper pistons settle and the correct lever travel is restored.

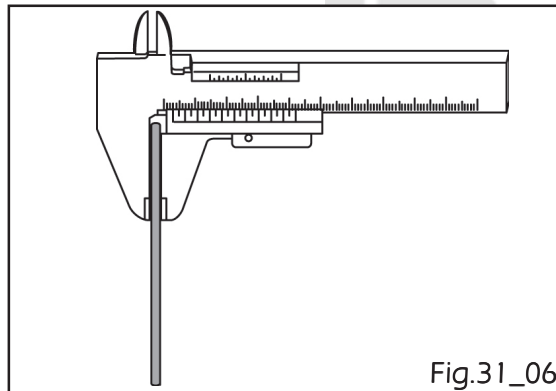

Brake discs

- Rest the vehicle on its centre stand and on level ground.
- Using a Vernier calliper, check the thickness of the brake disc.
- If the thickness is lower than the wear limit, have your disc replaced by an Authorised Service Centre.

Front disk thickness: 4 mm Wear limit: 3.5 mm

Rear disk thickness: 4 mm Wear limit: 3.5 mm



MAINTENANCE VEHICLE



6.15 HEADLIGHTS

To replace the high/low beam light bulbs, please contact your nearest Authorised Service Centre.

If you have the necessary tools and knowledge to carry out these operations yourself, you will find a detailed procedure in the relevant section of this vehicle's Workshop Manual that may be purchased at any Authorised Service Centre.

Daytime Running light : 12V LED

High/low/beam: 12V 35-35W

Direction Indicators: 12V LED



6.16 TAIL/BRAKE LIGHT AND DIRECTION INDICATORS.

The tail/brake light and direction indicator units fitted to this vehicle are sealed, maintenance free LED units.

Tail/Brake light: 12V LED

Direction Indicators: 12V LED



Fig.32_06

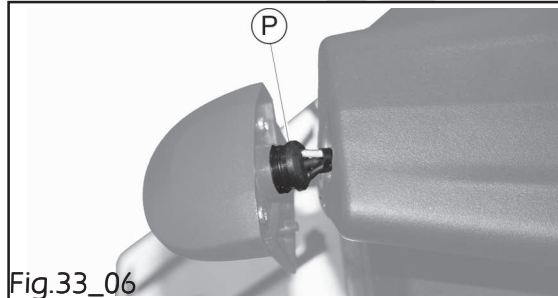

Fig.33_06

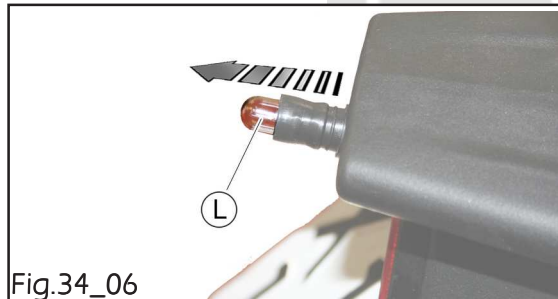

Fig.34_06

6.17 LICENCE PLATE LIGHT



WARNING

Before carrying out any of the operations described below, rest the vehicle on its centre-stand and ensure

To replace the license plate light bulb, proceed as follows:

- Release the screw shown in the figure.
- Rotate and then remove the bulb retainer «P».



ATTENTION

To avoid cable damage, do not pull the bulb retainer using the cables.

- Remove the number plate holder light support.
- Detach the bulb «L» from the retainer.
- Replace the bulb «L» with a new one.

Licence plate : 12V 5W

- Refit the license plate light unit following the above procedure in reverse order.



WARNING



ATTENTION

It is highly recommended that you have these operations performed by an authorised service centre or qualified personnel.



MAINTENANCE VEHICLE

6.18 SCHEDULED MAINTENANCE



To maintain the vehicle in a safe and reliable condition, the maintenance operations outlined in this section must be carried out as specified in the scheduled maintenance chart.

Any fault must be reported promptly to an Authorised Service Centre without waiting for the next scheduled maintenance service.

All scheduled maintenance services must be carried out at the specified times, even if the stated mileage has not yet been reached.



WARNING

Scheduled services must be carried out on time to ensure your warranty remains valid.

For any further information concerning warranty procedures and scheduled maintenance, please refer to the "Warranty Booklet".



Table key

- C: Replace
- I: Check/inspection
- D: EFI management software diagnostic
- A: Adjust
- I/C: Inspect and replace if necessary
- I/R: Inspect and top up if necessary
- I/A: Inspect and top up if necessary

Notes

- 1) replace the brake fluid every 2 years
- 2) check engine oil level every 1,000 km
- 3) replace coolant liquid every 2 years



MAINTENANCE VEHICLE

X1000											
Operation	Pag.	1	3	6	9	12	15	18	21	24	→
Engine oil	58	C	C	C	C	C	C	C	C	C	
Engine oil filter	60	C	C	C	C	C	C	C	C	C	
Final drive oil	61	C	I	C	I	C	I	C	I	C	
Injection system	MCA	D			D			D			
Throttle Control Free Play	MCA	I	I	I	I	I	I	I	I	I	
Steering wheel	MCA	I				I	I/C	I/C	I/C	I/C	
Battery Tension	64	I	I	I	I	I	I	I	I	I	
Fuel Filter	MCA	I			C			C			
Drive Belt	MCA	I	I	I/C	I/C	I/C	I/C	I/C	I/C	I/C	
Timing Chain	MCA									C	
Valve Clearance	MCA	I/A			I/A			I/A			
Air Filter	66	I	C	I	C	I	C	I	C	I	
Spark Plug	62			I	C	I		C		C	
Brake Pad s	72	I	I/C	I/C	I/C	I/C	I/C	I/C	I/C	I/C	
Brake Fluid Level	70	I/R	I/R	I/R	I/R	I/R	I/R	I/R	I/R	I/R	C
Coolant Level	69	I/R	I/R	I/R	I/R	I/R	I/R	I/R	I/R	I/R	C
Tyre Pressure and Wear	68	I/C	I/C	I/C	I/C	I/C	I/C	I/C	I/C	I/C	
Hydraulic Tilting system	MCA	I	I	I	I	I	I	I	I	I	
HTS oil	MCA	C			C			C			
Articulated parallelogram	MCA	I	I	I	I/C	I/C	I/C	I/C	I/C	I/C	
Front suspension bearing	MCA	I	I	I	I/C	I/C	I/C	I/C	I/C	I/C	
Fixed elements	MCA	I	I	I	I	I	I	I	I	I	
Mechanical caliper parking	MCA	I/A	I/A	I/A	I/A	I/A	I/A	I/A	I/A	I/A	
Automatic trasmission (driving belt, stepless speed change gear rollers clutch)	MCA	I	I	I/C	I/C	I/C	I/C	I/C	I/C	I/C	

Repeat services as from 3000 km



MAINTENANCE VEHICLE

ONLY ORIGINAL



SPARE PARTS

6.19 EXTRAORDINARY MAINTENANCE



Any extraordinary maintenance should be carried out by an Authorised Service Centre.

6.20 ACCESSORIES AND SPARE PARTS



Quadro recommends that only original spare parts be used in order to guarantee the same quality level of the components fitted to your vehicle as it leaves the factory.

The use of non-original spare parts renders the Warranty void.

Quadro markets its own line of spare parts and accessories that are approved and guaranteed for use. Contact an Authorised Service Centre to help you select and fit the correct spare part or accessory. The fitting of any non-approved parts and accessories may adversely affect the handling, stability or other aspect of the vehicle.

Be extremely careful when installing and removing the mechanical antitheft devices on the vehicle, e.g. disc locks, u-shaped padlocks, etc., particularly in the vicinity of brake hoses, cables, electric wires, etc.

An incorrect installation or removal of such antitheft devices as well as their non-removal before riding the vehicle may seriously damage its components and adversely affect its handling and stability that may result in an accident causing injury to the rider.

6.21 TROUBLESHOOTING GUIDE

The following table summarises a list of the many problems that may occur with their likely causes and possible fix.

Problem	Troubleshooting guide	
	Likely cause	Solution
Engine does not start	<ul style="list-style-type: none"> A. No fuel B. Excessive dirt/corrosion on Spark Plug C. Clogged air or fuel filter D. Flooded engine E. Blown fuse 	<ul style="list-style-type: none"> A. Check fuel level inside tank. B. Clean and replace spark plug. C. Clean filter. D. Remove spark plug and allow the fuel inside the cylinder to evaporate. E. Replace blown fuse and have vehicle inspected by an Authorised Service Centre.
Reduced braking power	<ul style="list-style-type: none"> A. Brake hose damaged B. Excessive wear of tyres or brake sealing C. Wax or grease on brake disc D. Worn brake pads E. Air in front and rear brake circuit 	<ul style="list-style-type: none"> A. Contact an Authorised Service Centre for the replacement. B. Contact an Authorised Service Centre for the replacement. C. Contact an Authorised Service Centre. D. Replace worn pads. E. Contact an Authorised Service Centre.
High noise levels	<ul style="list-style-type: none"> A. Excessive wear of bearings B. Damaged exhaust C. Cylinder head fault 	<ul style="list-style-type: none"> A. Contact an Authorised Service Centre for the replacement. B. Contact an Authorised Service Centre for the replacement. C. Contact an Authorised Service Centre for the replacement.
Vehicle does not move	<ul style="list-style-type: none"> A. Insufficient brake lever travel 	<ul style="list-style-type: none"> A. Check wear of brake pads.
Engine tends to die	<ul style="list-style-type: none"> B. Clogged air or fuel filter C. Clogged exhaust D. No fuel 	<ul style="list-style-type: none"> B. Clean filter. C. Contact an Authorised Service Centre. D. Check fuel level inside tank.
Low compression	<ul style="list-style-type: none"> A. Loosen spark plug C. Loosen cylinder head or excessive wear of piston retaining rings 	<ul style="list-style-type: none"> A. Tighten the spark plug C. Contact an Authorised Service Centre for the replacement.
Suspensions are ineffective	<ul style="list-style-type: none"> A. Dampers faulty, oil leaks, worn stop buffers. 	<ul style="list-style-type: none"> A. Contact an Authorised Service Centre.
Poor performance, high fuel consumptions	<ul style="list-style-type: none"> A. Air filter clogged or dirty. 	<ul style="list-style-type: none"> A. Clean filter



MAINTENANCE VEHICLE

6.22 TYRE PUNCTURE

This vehicle is fitted with tubeless tyres. In the event of a puncture, these tyres will deflate slowly, providing the rider with a safer ride. For any repair, please contact an Authorised Service Centre or Dealer.



To replace any of your vehicle's tyres, please contact an Authorised Service Centre.



Do not fit inner tubes to tubeless tyres.

6.23 CLEANING THE VEHICLE



Before cleaning your vehicle ensure that it is parked safely and with the engine off.
Avoid direct water sprays directed at the engine.

Mud and dirt must be removed with a soft sponge for bodywork soaked in water and shampoo. Rinse abundantly with water, and dry with a clean cloth.
For engine clean, use specific degreasing products.



When cleaning the vehicle, the brake discs and pads may come into contact with water and degreasing products. This may lead to a temporary decrease of the stopping power. Repeatedly activate the brakes to restore the normal conditions.



If you use a high-pressure washer to clean your vehicle, be careful not to direct it towards sensitive parts of the vehicle (electrical parts, engine, etc.) or people, animals and objects in the vicinity.



6.25 RECOMMENDED PRODUCTS

To guarantee an optimal performance from your vehicle, **Quadro** recommends the following products:

Descrizione	Specifiche
Engine oil	SAE 10W-60 API-SJ
Final drive oil	SAE 80W-90
Brake fluid	DOT 4
Coolant	CUNA NC 956-16
HTS system oil	Motorex SAE 10W



DO NOT USE ANY PRODUCT THAT DOES NOT MEET THE SPECIFICATIONS LISTED ABOVE AS THIS MAY ADVERSELY AFFECT THE HANDLING AND STABILITY OF THE VEHICLE AND RESULT IN SERIOUS INJURIES.



6.25 TOOL KIT

The vehicle is a tool kit
The kit contains the following tools:

- Socket wrench
- Double screwdriver





Quadro 350D



CHAP.7 VEHICLE STORAGE GUIDE





VEHICLE STORAGE GUIDE

7.1 VEHICLE INACTIVITY

In the event that the vehicle is not going to be ridden for a long period of time, such as during winter, or for any other reason, special precautions requiring suitable knowledge, tools and equipment must be observed. For this reason, Quadro recommends that these operations are performed by an authorised service centre. If this is not possible, please follow the instructions provided below.

VEHICLE

Clean the vehicle thoroughly and rest it on its centre stand on level ground, ensuring that it is sufficiently stable. Release the parking brake using the lever in order to prevent any damage to the tilting mechanism as a result of the tensions within the system. Turn the handlebar fully to the left, then rotate the ignition key to the lock position and remove it from the switch.

FUEL

Fill the fuel tank with the correct grade of unleaded fuel and add a fuel stabiliser, following the fuel stabiliser manufacturer's instructions.

BATTERY

- 1) Remove the battery following the instructions provided within the BATTERY section of this booklet.
- 2) Clean the exterior of the battery with a soft detergent and remove any sign of corrosion from the terminals and the leads.
- 3) Store the battery in a safe place.
- 4) Once a month, recharge the battery to the value 1.2 A for between 5 to 10 hours



VEHICLE STORAGE GUIDE

TYRES

Inflate the tyres as prescribed.

EXTERIOR

- Spray a suitable lubricant on all rubber parts of the vehicle
- Spray rust inhibiting oil on all unpainted metal surfaces to prevent rusting
- Wax all painted surface using car wax



Petrol (fuel) is highly flammable and explosive. Handling fuel is highly dangerous and may result in injuries or even death. Store the vehicle in a well ventilated area. Seal the container immediately after handling petrol. Ensure that there are no fuel leaks during refuelling. Petrol vapours and / or any leaks could ignite. Immediately clean the entire area. Store fuel away from sources of heat and fire or sparks





Quadro 350D



CHAP.8 DISMANTLING AND DISPOSAL





DISMANTLING AND DISPOSAL

8.1 VEHICLE DISMANTLING AND DISPOSAL



WARNING

All dismantling operations carried out on the vehicle must be compatible and should strictly follow the operator's safety regulations.



Before setting out to perform any dismantling operation you must ensure that any item that might cause injuries is safely put away and that you must wear protective clothes, gloves and safety shoes. You must also be in good health and are not under the influence of alcohol or any other drugs.

This vehicle has been manufactured using recyclable metals (frame, engine, wheel rims, mechanisms, etc.) and plastics (fibreglass, seals, tyres, etc.) that do not require special treatments for their disposal.

When dismantling the vehicle, plastic parts should be nonetheless separated from ferrous materials so as to send them to different waste collections in compliance with the regulations in the country where the vehicle is used.

As for the metal parts of the vehicle, it is sufficient to divide between steel and other metals or alloys for their proper delivery to melting recycling.



WARNING



Disposal of vehicle components must be done respecting the environment, avoiding pollution of soil, water and air and in compliance with the regulations in force.



DECOMMISSIONING AND DISPOSAL



We remind you that the disposal of vehicle components and polluting substances must be carried out in accordance with the law.



ATTENTION

You are responsible for keeping up with the regulations concerning the disposal of harmful substances in accordance with the law.



ATTENTION

When disposing of the vehicle, the user is obliged to destroy all identification plates and relative documentation.









Edito da: **ITALIA DESIGN** Caprona di Vicopisano - (PI)

THIS AREA IS RESERVED FOR BAR CODE



Quadro Vehicles S.A.
Email: infoquadro4motion.com
www.quadro4motion.com